

MForce MicroDrive Motion Control Integrated Controller and Driver

MFORCETM
MICRO DRIVE
Plus
MOTION CONTROL



IMS
is becoming
Schneider
Electric

IMSTM INTELLIGENT MOTION
SYSTEMS, INC.

Important information

The drive systems described here are products for general use that conform to the state of the art in technology and are designed to prevent any dangers. However, drives and drive controllers that are not specifically designed for safety functions are not approved for applications where the functioning of the drive could endanger persons. The possibility of unexpected or un-braked movements can never be totally excluded without additional safety equipment. For this reason personnel must never be in the danger zone of the drives unless additional suitable safety equipment prevents any personal danger. This applies to operation of the machine during production and also to all service and maintenance work on drives and the machine. The machine design must ensure personal safety. Suitable measures for prevention of property damage are also required.

Qualification of personnel

Only technicians who are familiar with and understand the contents of this manual and the other relevant documentation are authorized to work on and with this drive system. The technicians must be able to detect potential dangers that may be caused by setting parameters, changing parameter values and generally by the operation of mechanical, electrical and electronic equipment.

The technicians must have sufficient technical training, knowledge and experience to recognise and avoid dangers.

The technicians must be familiar with the relevant standards, regulations and safety regulations that must be observed when working on the drive system.

Intended Use

The drive systems described here are products for general use that conform to the state of the art in technology and are designed to prevent any dangers. However, drives and drive controllers that are not specifically designed for safety functions are not approved for applications where the functioning of the drive could endanger persons. The possibility of unexpected or unbraked movements can never be totally excluded without additional safety equipment.

For this reason personnel must never be in the danger zone of the drives unless additional suitable safety equipment prevents any personal danger. This applies to operation of the machine during production and also to all service and maintenance work on drives and the machine. The machine design must ensure personal safety. Suitable measures for prevention of property damage are also required.

In all cases the applicable safety regulations and the specified operating conditions, such as environmental conditions and specified technical data, must be observed.

The drive system must not be commissioned and operated until completion of installation in accordance with the EMC regulations and the specifications in this manual. To prevent personal injury and damage to property damaged drive systems must not be installed or operated.

Changes and modifications of the drive systems are not permitted and if made all no warranty and liability will be accepted.

The drive system must be operated only with the specified wiring and approved accessories. In general, use only original accessories and spare parts.

The drive systems must not be operated in an environment subject to explosion hazard (ex area).

This page intentionally left blank

Table of Contents

Getting Started	1-1
Before You Begin.....	1-1
Tools and Equipment Required.....	1-1
Connecting the Power Supply.....	1-1
Connecting Communications.....	1-1
Connecting the Motor.....	1-1
Minimum Required Connections.....	1-1
Install IMS Terminal Software.....	1-2
Establishing Communications.....	1-3
Apply Power to the MForce.....	1-4
Testing the MForce.....	1-4
Make the MForce Move.....	1-4
Motion Control Example Using Program Mode.....	1-5
Programming Notes.....	1-5

Part 1: Hardware Specification

Section 1.1: Product Introduction	1-9
Introduction.....	9
Feature Summary – Standard and Plus2 Expanded.....	9
Standard Features.....	9
Expanded Features – Available only in the Plus2 Version.....	10

Section 1.2: Motion Control MForce MicroDrive Detailed Specifications	1-11
Standard Electrical Specifications.....	1-11
Mechanical Specifications.....	1-13
Pin/Wire Assignments and Description.....	1-13
P1 Connector - I/O and Power Connections.....	1-13
P1 Connector Options.....	1-14
P2 Connector - RS-422/485 Communications.....	1-14
P2 Connector Options.....	1-15
P3 Connector - Motor Phase Connector.....	1-15
P3 Connector.....	1-15
Accessories.....	1-16
Motors and Encoders.....	1-16
Power Supplies.....	1-16
Connectivity.....	1-16
QuickStart Kit.....	1-16
Communication Converter Cables.....	1-16
Mating Connector Kits.....	1-16
Prototype Development Cables.....	1-16

Section 1.3: MForce MicroDrive Plus² Expanded Specifications	1-17
Plus2 Electrical Specifications.....	1-17
Mechanical Specifications.....	1-19
Pin Assignments and Description.....	1-20
P1 Connector - Power and Expanded I/O Configuration.....	1-20
P1 Connector - Power and I/O with Remote Encoder Configuration.....	1-20
P1 Connector.....	1-21
P2 Connector - RS-422/485 Communications.....	1-21
P3 Connector - Motor Phase Connector.....	1-22
P2 Connector Options.....	1-22
P3 Connector.....	1-22
Accessories.....	1-23
Motors and Encoders.....	1-23
Power Supplies.....	1-23
Connectivity.....	1-23
QuickStart Kit.....	1-23
Communication Converter Cables.....	1-23
Prototype Development Cable.....	1-23
Mating Connector Kits.....	1-23

Part 2: Connections and Interface

Section 2.1: Mounting and Connection Recommendations	2-3
Mounting Recommendations.....	2-3
DC Power Recommendations	2-3
Layout and Interface Guidelines.....	2-3
Rules of Wiring	2-4
Rules of Shielding	2-4
Securing Power Leads and Logic Leads	2-4
Recommended Wiring.....	2-5
Recommended Mating Connectors and Pins.....	2-5
Communications.....	2-5
I/O, Power and Remote Encoder.....	2-5
Motor.....	2-5
Section 2.2: Motor Sizing and Selection	2-7
Choosing a Power Supply for Your MForce MicroDrive.....	2-7
DC Power Supply Recommendations.....	2-8
MForce MicroDrive	2-8
Recommended IMS Power Supplies	2-8
Connecting DC Power.....	2-8
Recommended Power and Cable Configurations	2-9
Example A – Cabling Under 50 Feet, DC Power	2-9
Example B – Cabling 50 Feet or Greater, AC Power to Full Wave Bridge	2-9
Example C – Cabling 50 Feet or Greater, AC Power to Power Supply	2-9
Recommended Power Supply Cabling.....	2-10
Aux-Logic Supply Connection	2-10
Section 2.3: Motor Sizing and Selection	2-11
Selecting a Motor	2-11
Types and Construction of Stepping Motors	2-11
Sizing a Motor for Your System	2-11
Recommended IMS Motors	2-12
IMS Inside Out Stepper Motors.....	2-13
Motor Wiring.....	2-14
Connecting the Motor	2-14
8 Lead Motors	2-14
6 Lead Motors.....	2-15
4 Lead Motors.....	2-16
Recommended Motor Cabling	2-17
Example A: Motor Cabling Less Than 50 Feet.....	2-17
Example B: Motor Cabling Greater Than 50 Feet	2-17
Recommended Motor Cable AWG Sizes	2-18
Section 2.4 Interfacing Communications	2-19
Available Communications Cables/Converters	2-19
Interfacing Single Mode Communications	2-19
Single Mode Communications Full Duplex (RS-422)	2-19
Single Mode Communications Half Duplex (RS-485)	2-20
Interfacing Party Mode Communications.....	2-20
Data Cable Termination Resistors.....	2-20
Avoiding Communications Ground Loops in Party Mode.....	2-21
Multi-drop Wiring: Non-Isolated Communications	2-22
Multi-drop Wiring: Isolated Communications	2-23
MForce MicroDrive Communication Format	2-24
MForce MicroDrive Response to Echo Mode.....	2-24
Using Check Sum.....	2-25
MForce MicroDrive Party Mode Sample Codes	2-26
MForce MicroDrive Immediate Party Mode Sample Codes.....	2-27

Section 2.5: Interfacing and Using the MFI I/O.....	2-29
The MForce MicroDrive Digital I/O	2-29
Standard I/O Set	2-29
Enhanced I/O Set - MForce MicroDrive Plus2 Version	2-29
Uses of the Digital I/O	2-29
MForce MicroDrive Digital Input Functions	2-30
Input Functions (I/O Points 1-4, 9-12)	2-30
Input Functions (Points 7 & 8 — Clock Inputs and Point 13 — Capture)	2-31
Active States Defined.....	2-31
MForce MicroDrive Digital Output Functions	2-31
Programmable Output Functions	2-32
Output Functions (Points 7 & 8 — Clock Outputs and Point 13 — Trip).....	2-32
MForce MicroDrive I/O Ratings.....	2-33
MForce Standard I/O Connections	2-33
MForce Expanded Plus2 I/O Connections.....	2-34
I/O Usage Examples — MForce MicroDrive Standard I/O Set	2-35
Input Interface Example - Switch Input Example (Sinking Input)	2-35
Input Interface Example - Switch Input Example (Sourcing Input)	2-36
Output Interface Example (Sinking Output).....	2-37
General Purpose I/O Usage Examples — Enhanced I/O Set	2-38
Input Interface Example - Switch Input Example (Sinking Input)	2-38
Input Interface Example - Switch Input Example (Sourcing Input)	2-39
Output Interface Example (Sinking Output).....	2-40
Output Interface Example (Sourcing Output)	2-41
Dedicated Digital I/O - Enhanced I/O Set.....	2-42
Step/Direction/Clock I/O	2-42
Capture/Trip	2-43
Interfacing the Analog Input	2-44
Sample Usage	2-44

Appendices

Appendix A: CANopen Communications.....	A-3
Features.....	A-3
Communications Specifications	A-3
Interfacing The CAN Bus	A-3
CAN Bus Connections.....	A-3
Pin Assignments.....	A-4
Recommended CANopen Dongle.....	A-4
Interface Cable Construction	A-4
Installation Instructions.....	A-4
CANopen Tester Quick Start.....	A-6
Installation	A-6
Getting Started.....	A-6
Appendix B: I/O Application Guide.....	A-7
Standard I/O Set Interfacing and Application.....	A-9
NPN Sinking Input.....	A-9
PNP Sourcing Input.....	A-10
Sinking Output	A-11
Mixed Input/Output Example.....	A-11
Enhanced I/O Set Interfacing and Application	A-12
NPN Sinking Input.....	A-12
PNP Sourcing Input.....	A-12
Sourcing Output	A-13
Mixed Input/Output Example.....	A-14
Interfacing Inputs as a Group Example.....	A-14
Interfacing Outputs as a Group Example.....	A-15

Appendix C: Encoder Options	A-17
MForce Motion Control Closed Loop Options.....	A-17
Remote Differential Encoder - MForce MicroDrive Plus2.....	A-17
Encoders Available from IMS.....	A-17
General Specifications.....	A-17
Encoder Signals.....	A-18
Differential Encoder.....	A-18
Characteristics.....	A-18
Encoder Cables.....	A-19
Recommended Encoder Mating Connectors.....	A-19
Appendix D: Connectivity	A-21
MD-CC40x-001 Communications Cable.....	A-21
Electrical Specifications.....	A-21
MD-CC400-001 Mechanical Specifications and Connector Details.....	A-21
MD-CC402-001 Mechanical Specifications and Connection.....	A-23
Installation Procedure for the MX-CC40x-000.....	A-25
Installing the Cable/VCP Drivers.....	A-25
Determining the Virtual COM Port (VCP).....	A-26
Prototype Development Cable PD10-1434-FL3 For Multi-Drop Communications.....	A-27
Setup Instructions — Cable #1.....	A-27
Setup Instructions — Cable #2 and Subsequent MForces.....	A-27
MForce MicroDrive Recommended Prototype Development Cable.....	A-28
P1: PD16-1417-FL3 — Power and I/O.....	A-28
Prototype Development Cable PD04-MF34-FL3.....	A-29
Appendix E: IMS Enhanced Torque Stepping Motors	A-31
Size 14 Enhanced Torque Stepping Motor.....	A-31
General Specifications.....	A-31
Wiring And Connection.....	A-31
Mechanical Specifications.....	A-31
Size 17 Enhanced Torque Stepping Motor.....	A-32
General Specifications.....	A-32
Wiring And Connection.....	A-32
Mechanical Specifications.....	A-32
Size 23 Enhanced Torque Stepping Motor.....	A-33
General Specifications.....	A-33
Wiring And Connection.....	A-33

List of Figures

Figure GS.1: MForce MicroDrive Minimum Required Connections.....	1-2
Figure GS.2: Product CD Entry and Installation Screens.....	1-2
Figure GS.3: IMS Terminal Main Screen.....	1-3
Figure GS.4: IMS Terminal Preferences Dialog.....	1-3
Figure GS.5 Motion Control MForce MicroDrive Sign-On Message.....	1-4
Figure GS.6: Download the Program.....	1-5

Part 1: Hardware Specification

Figure 1.1.1: MForce MicroDrive With 7-Pin Terminal Strip.....	1-9
Figure 1.1.2: MForce MicroDrive Plus ² Wire Crimp.....	1-9
Figure 1.2.1: Mechanical Specifications.....	1-13
Figure 1.2.2: P1 Wire Color and Pin Assignment.....	1-14
Figure 1.2.3: P2 Pin Assignment.....	1-15
Figure 1.2.4: P3 — 4-Pin Locking Wire Crimp Motor Connector.....	1-15
Figure 1.3.1: Mechanical Specifications.....	1-19
Figure 1.3.2: 16-Pin Wire Crimp Connector P1 Pin Numbers.....	1-21
Figure 1.3.3: P2 Pin Assignment.....	1-22
Figure 1.3.4: P3: 4-Pin Locking Wire Crimp Motor Connector.....	1-22

Part 2: Connections and Interface

Figure 2.1.1: MForce MicroDrive Mounting Recommendations.....	2-3
Figure 2.1.2: Grounding and Shielding for Logic Connections.....	2-4
Figure 2.2.1: IMS ISP300 Switch Mode Power Supply.....	2-7
Figure 2.2.2: MForce MicroDrive Power Connections	2-8
Figure 2.2.4: DC Cabling - Under 50 Feet.....	2-9
Figure 2.2.5: DC Cabling - 50 Feet or Greater - AC To Full Wave Bridge Rectifier	2-9
Figure 2.2.6: AC Cabling - 50 Feet or Greater - AC To Power Supply	2-9
Figure 2.2.7: Aux-Logic Connection	2-10
Figure 2.3.1 A & B: Per Phase Winding Inductance.....	2-12
Figure 2.3.2: 8 Lead Motor Series Connections.....	2-14
Figure 2.3.3: 8 Lead Motor Parallel Connections.....	2-15
Figure 2.3.4: 6 Lead Half Coil (Higher Speed) Motor Connections	2-15
Figure 2.3.5: 6 Lead Full Coil (Higher Torque) Motor Connections	2-16
Figure 2.3.6: 4 Lead Motor Connections.....	2-16
Figure 2.3.7: Motor Cabling Less than 50 Feet.....	2-17
Figure 2.3.8: Motor Cabling Greater than 50 Feet.....	2-17
Figure 2.4.1: Full Duplex Communications (RS-422).....	2-19
Figure 2.4.2: Half Duplex 2 Wire Communications (RS-485)	2-20
Figure 2.4.3: RS-485 Interface, Multiple MForce MicroDrive System.....	2-21
Figure 2.4.4: Multi-drop Connection using a Non-Isolated Comm Converter	2-22
Figure 2.4.5: Multi-drop Connection using an Isolated Comm Converter	2-23
Figure 2.5.1: Uses for the Digital I/O.....	2-29
Figure 2.5.2: Flying Lead I/O Connections.....	2-33
Figure 2.5.3: 7-Pin Pluggable Terminal I/O Connections.....	2-33
Figure 2.5.4: Plus 2 I/O Connections - Expanded I/O Configuration	2-34
Figure 2.5.5: Plus 2 I/O Connections - Closed Loop Configuration.....	2-34
Figure 2.5.6: Sinking Input Example using a Push Button Switch	2-35
Figure 2.5.7: Sourcing Input Example using a Push Button Switch	2-36
Figure 2.5.8: Sinking Output Example.....	2-37
Figure 2.5.9: Switch Interface to Input, Sinking.....	2-38
Figure 2.5.10 Sourcing Input Example using a Push Button Switch	2-39
Figure 2.5.11: Sinking Output Example.....	2-40
Figure 2.5.12: Sourcing Output Example.....	2-41
Figure 2.5.13: MForce MicroDrive Clock Functions.....	2-42
Figure 2.5.14: Step Direction I/O Equivalent Circuit.....	2-42
Figure 2.5.15: Capture/Trip I/O Equivalent Circuit.....	2-43
Figure 2.5.16: Analog Input - Voltage Mode	2-44
Figure 2.5.17: Analog Input - Current Mode	2-45

Appendices

Figure D.1: CANOpen Network using MForce PowerDrive.....	A-3
Figure D.2: DB-9 Pin Configuration	A-4
Figure D.3: MD-CC500-000 and Interface Cable.....	A-5
Figure D.4: CANOpen Tester Interface Showing Getting Started Sequence.....	A-6
Figure B.1: NPN Interface to an MForce Sinking Input.....	A-9
Figure B.2: PNP Interface to a Sourcing Input	A-10
Figure B.3: Sinking Output to Relay	A-11
Figure B.4: Mixed Output Example- Standard I/O Set.....	A-11
Figure B.5: NPN Sinking Input on an MForce Plus ² Motion Control	A-12
Figure B.6: PNP Sourcing Input on an MForce Plus ² Motion Control.....	A-12
Figure B.7: Sourcing Output to Sourcing Input	A-13
Figure B.8: Mixed Input/Output Example - Enhanced I/O.....	A-14
Figure B.9: TTL Interface to an Input Group.....	A-14
Figure B.10: Outputs Interfaced to LED's as a Group	A-15
Figure C.1: Connecting a Remote Encoder	A-17
Figure C.2: Differential Encoder Signals.....	A-18
Figure D.1: MD-CC400-001 Mechanical Specifications and Connection.....	A-21
Figure D.2: 10-Pin IDC.....	A-22
Figure D.3: Configuring the MD-CC400-001 for Multi-drop Communications	A-22
Figure D.4: MD-CC402-000 Mechanical Specifications and Connection.....	A-23
Figure D.5: 10-Pin Wire Crimp	A-23
Figure D.6: Configuring the MD-CC402-001 for Multi-drop Communications	A-24
Figure D.7: Hardware Update Wizard.....	A-25
Figure D.8: Hardware Update Wizard Screen 2.....	A-25

Figure D.9: Hardware Update Wizard Screen 3.....	A-25
Figure D.10: Windows Logo Compatibility Testing	A-26
Figure D.11: Hardware Update Wizard Finish Installation.....	A-26
Figure D.12 Hardware Properties.....	A-26
Figure D.13: Windows Device Manager.....	A-26
Figure D.14: PD16-1417-FL3 Prototype Development Cable	A-28
Figure D.15: 16-Pin Wire Crimp	A-28
Figure D.16: PD04-MF34-FL3.....	A-29
Figure D.17: 4-Pin Wire Crimp	A-29
Figure E.1: Size 14 Wiring and Connection	A-31
Figure E.2: Size 14 Mechanical Specifications.....	A-31
Figure E.3: Size 17 Wiring and Connection	A-32
Figure E.4: Size 17 Mechanical Specifications.....	A-32
Figure E.5: Size 23 Wiring and Connection	A-33
Figure E.6: Size 23 Mechanical Specifications.....	A-33

List of Tables

Table GS.1: Minimum Required Connections	1-1
--	-----

Part 1: Hardware Specification

Table 1.2.1: P1 — Pin Assignment, Power and I/O.....	1-13
Table 1.2.2: P2 — Pin Assignment, RS-422/485 Communications.....	1-14
Table 1.2.3: P3 — Pin Assignment, Motor Phase Connections	1-15
Table 1.3.1: P1 — Pin Assignment, Expanded I/O Configuration	1-20
Table 1.3.2: P1 — Pin Assignment, Remote Encoder Configuration.....	1-20
Table 1.3.3: P2 — Pin Assignment, RS-422/485 Communications.....	1-21
Table 1.3.4: P3 — Pin Assignment, Motor Phase Connections	1-22

Part 2: Connections and Interface

Table 2.2.1: Recommended Supply Cables.....	2-10
Table 2.3.1: Recommended Wire Gauges.....	2-18
Table 2.4.1: Response to Echo Mode - Party and Check Sum are Zero (0)	2-24
Table 2.4.3: Response to Echo Mode - Party is Zero (0) and Check Sum is One (1)	2-25
Table 2.4.4: Response to Echo Mode - Party and Check Sum are One (1)	2-25
Table 2.5.1: Programmable Input Functions.....	2-30
Table 2.5.2: Dedicated Input Functions	2-31
Table 2.5.3: Programmable Output Functions	2-32
Table 2.5.4: Dedicated Output Functions	2-32
Table 2.4.5: MForce MicroDrive I/O and Protection Ratings.....	2-33

Appendices

Table D.1: CANopen Communications Specifications.....	A-3
Table D.2: DB-9 Pin Assignments and Description.....	A-4
Table B.1: Output Bit Weight Examples - Outputs set as a group	A-15
Table C.1: Available Encoder Line Counts, Part Numbers and Pin Configurations	A-17
Table D.2: PD10-1434-FL3 Wire Color Codes.....	A-27
Table D.3: PD16-1417-FL3 Wire Color Codes.....	A-28
Table D.4: PD04-MF34-FL3 Wire Color Codes.....	A-29
Table E.1: Size 14 General Specifications.....	A-31
Table E.2: Size 17 General Specifications.....	A-32
Table E.3: Size 23 General Specifications.....	A-33

GETTING STARTED

Getting Started



WARNING! Please ensure that you read the sections of the product manual pertaining to the MForce MicroDrive model you purchased in their entirety prior to placing the unit into full operation.

Before You Begin

A printed Quick Reference guide designed to help get you connected and communicating with the MForce is shipped with your product. The following examples will help you get the motor turning for the first time and introduce you to Immediate and Program modes of operation.

Immediate Mode: In Immediate Mode, commands are issued and executed directly to the MForce MicroDrive by user input into the terminal window of the IMS Terminal Program, shown later in this section.

Program Mode: Program mode is used to input user programs into the Motion Control MForce MicroDrive .

Tools and Equipment Required

- Motion Control MForce MicroDrive.
- NEMA Size 14, 17 or 23 frame stepping motor.
- Communications Converter Cable IMS P/N MD-CC400-000 or equivalent (USB to RS-422).
- Product CD or internet access to www.imshome.com.
- A +12 to +48 VDC unregulated power supply.
- Basic tools: wire cutters / strippers / screwdriver.
- 20 AWG wire for power supply.
- 20 AWG wire for motor or optional prototype development cable IMS P/N PD04-MF17-FL3.
- A PC with Windows XP Service Pack 2.
- A free serial communications or USB port.

Connecting the Power Supply

Using 20 AWG wire, connect the DC output of the power supply to the +V input of the MForce MicroDrive.

Connect the power supply ground to the Power Ground pin appropriate for your MForce MicroDrive. See Figure GS.1.

Connecting Communications

Connect the Host PC to the Motion Control MForce MicroDrive using the IMS Communications Converter Cable MD-CC400-000 or equivalent. See Figure GS-1.

Connecting the Motor

In accordance with the motor manufacturer documentation, connect the Motor Phases to the MForce MicroDrive Connector P4 (Prototype Development Cable IMS P/N PD04-MF17-FL3 recommended). See Figure GS.1.

Minimum Required Connections

The following Table and Diagram illustrate the minimum required connections to operate the MForce MicroDrive.

Minimum Required Connections			
Connector P1	Flying Leads	7-Pin Terminal	16-Pin Wire Crimp
+12 to +48 VDC	Red	Pin 7	Pin 15
Power Ground	Black	Pin 6	Pin 16
Connector P2	10 Pin IDC	10 Pin Wire Crimp	
TX+	Pin 1	Pin 9	
TX -	Pin 2	Pin 10	
RX +	Pin 3	Pin 7	
RX -	Pin 4	Pin 8	
COMM GND	Pin 10	Pin 2	
Connector P4	4-Pin Locking Wire Crimp		
Motor Phase \bar{A}	Pin 1		
Motor Phase A	Pin 2		
Motor Phase \bar{B}	Pin 3		
Motor Phase B	Pin 4		

Table GS.1: Minimum Required Connections



WARNING:
Do not connect or disconnect DC input to the MForce MicroDrive with power applied! Disconnect the AC power side to power down the DC Supply.

For battery operated systems, conditioning measures should be taken to prevent device damage caused by in-rush current draws, transient arcs and high voltage spikes.

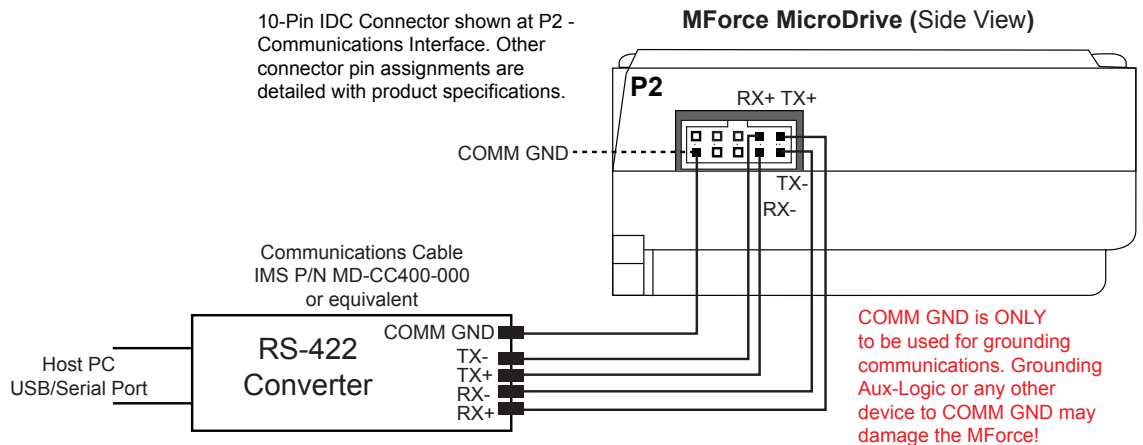
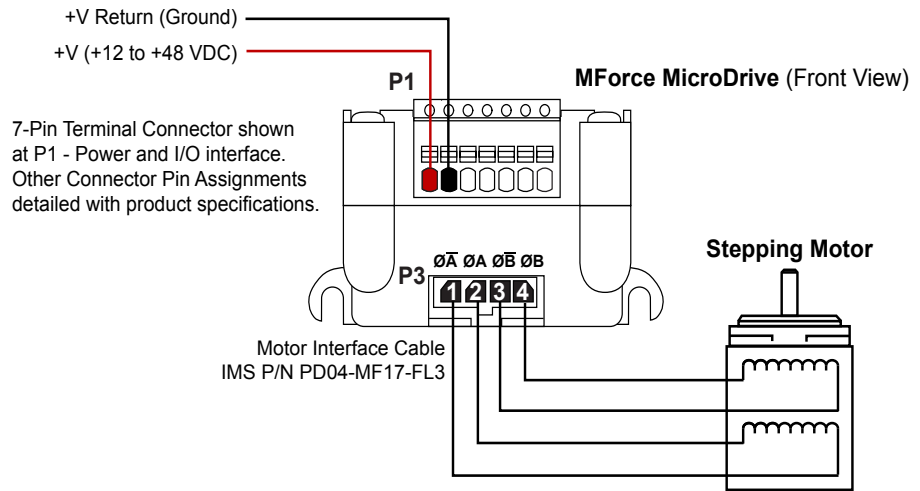

Figure GS.1: MForce MicroDrive Minimum Required Connections

Install IMS Terminal Software

IMS Terminal is an integrated ASCII text editor and terminal emulator designed to easily communicate with and program IMS Motion Control products. Using this freely provided program will eliminate the added complication of configuring and using a separate text editor and terminal software.

1. Insert the CD included with the product into the CD Drive of your PC.
If not available, go to http://www.imshome.com/software_interfaces.html.
2. The CD will autostart.
3. Click the Software Button in the top-right navigation Area.
4. Click the IMS Terminal link appropriate to your operating system.
5. Click SETUP in the Setup dialog box and follow the on-screen instructions.
6. Once IMS Terminal is installed, the Communications Settings can be checked and/or set.



Note: Interactive Tutorials covering the installation and use of the IMS Terminal are located on the IMS Web Site at <http://www.imshome.com/tutorials.html>.

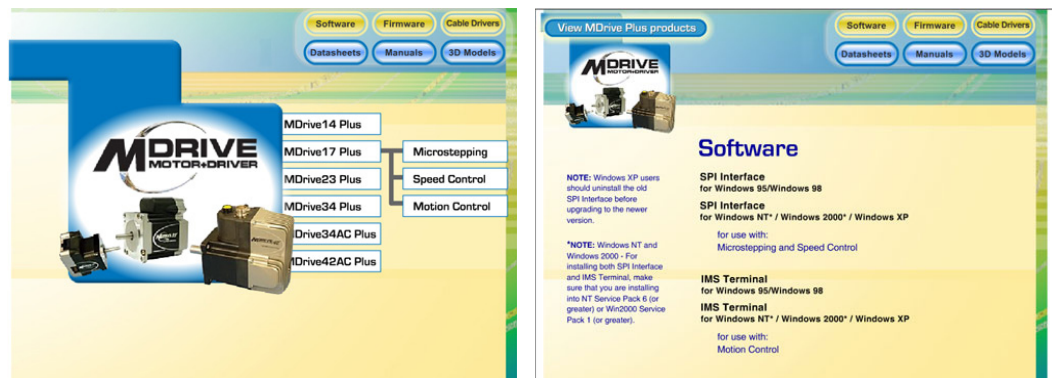

Figure GS.2: Product CD Entry and Installation Screens

Establishing Communications

1. Open IMS Terminal by clicking Start>Programs>IMS Terminal>IMS Term. The Program Edit Window (left) and Terminal Window (right) will be displayed.

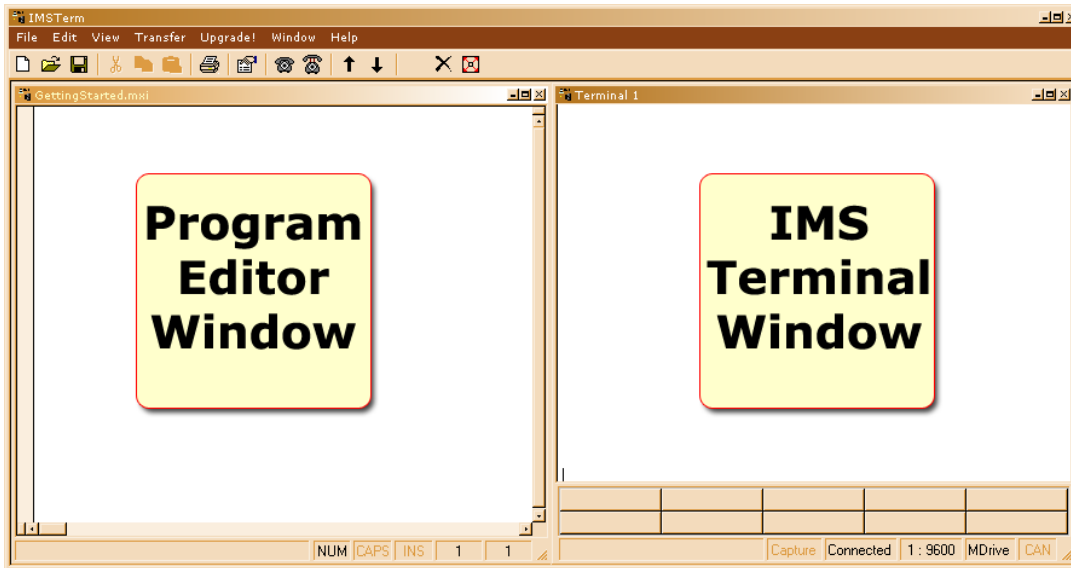

Figure GS.3: IMS Terminal Main Screen

2. On the Menu Bar click Edit / Preferences to open the Preferences dialog box.
3. Click on the Comm Settings tab to open the Comm Settings page.
 - a. Set Scroll Back to desired range of text lines to be displayed.
 - b. Under Device, confirm MDrive has been selected and also verify the Comm Port being used. Do not change any other settings. Click "OK".

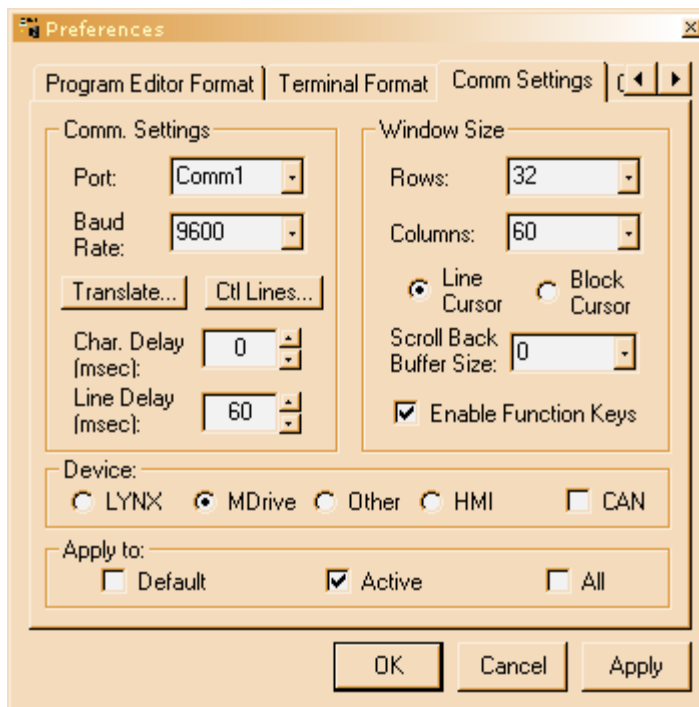

Figure GS.4: IMS Terminal Preferences Dialog

N **Note:** Entering MForce MicroDrive commands directly into the Terminal Window is called "Immediate Mode".

The Motion Control MForce MicroDrive command set is not case sensitive except for command DN = < >

Warning: If you have installed the MForce MicroDrive to a load, be sure the load can safely be moved before testing.

Tip: A small piece of tape on the motor shaft is a visual aid to help see the shaft turning.

Apply Power to the Motion Control MForce MicroDrive

1. Verify that all connections have been made, then apply power to the Motion Control MForce MicroDrive. Click on the Phone icon or the Disconnect status box to establish communications between IMS Terminal and the MForce MicroDrive. The following sign-on message should appear in the Terminal Window:

```
"Copyright 2001-2006 by Intelligent Motion Systems, Inc."
```

2. If you can see the sign-on message, then the MForce MicroDrive is properly powered-up and communicating.
 - a. If the sign-on message does not appear, try using a software reset. Hold down the "Ctrl" key and press "C". If the sign-on message still does not appear, check all connections, as well as all hardware and software configurations, then start IMS Terminal again.
3. You are now connected and communicating to the Motion Control MForce MicroDrive.
Note: There are indicators at the bottom of the Terminal Window that show whether you are connected or disconnected, the current Baud Rate, and the type of device (MDrive displayed when using MForce) for which the IMS Terminal is configured. These three items may be changed directly from this screen by double clicking on each of them.

Testing the Motion Control MForce MicroDrive

1. Click in the Terminal Window, and type (followed by ENTER):
PR VM
2. The Motion Control MForce MicroDrive will return a value of 768000
3. Type the following in the Terminal Window (followed by ENTER):
VM=360000
PR VM
4. The Motion Control MForce MicroDrive will return a value of 360000
5. Type FD and press ENTER. (FD = Factory Defaults)

```
"Copyright 2001-2006 by Intelligent Motion Systems, Inc."
```

should appear in the Terminal Window within a few seconds.

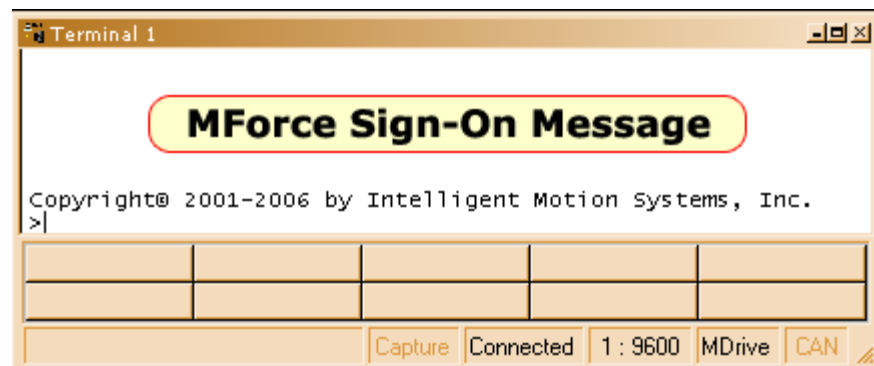

Figure GS.5 Motion Control MForce MicroDrive Sign-On Message

Make the Motion Control MForce MicroDrive Move

1. Type MR 51200 into the Terminal Window and press ENTER. (MR = Move Relative)
 - a. With the default settings, the MForce Motion Control should move one revolution in approximately 0.066 seconds, or at a velocity of 15 revolutions per second.
2. Type SL 102400 and press ENTER. (SL = Slew)
 - a. With the default settings, the Motion Control MForce MicroDrive should run constantly at a speed of approximately 2 revolutions per second or 120 revolutions per minute.
3. Type SL 0 and press ENTER. The Motion Control MForce MicroDrive should decelerate to a full stop.

Motion Control Example Using Program Mode

1. Click on drop-down menu View > New Edit Window to open the Program Edit Window.
2. Type “XYZ Test” into the “Open a New file for editing” dialog box, and click “OK”.
3. Click anywhere within the Program Edit Window, and type (followed by ENTER):

```
VA LP=0      `user variable name LP = start count 0
A=100000    `set acceleration to 100000 steps/sec2
D=100000    `set deceleration to 100000 steps/sec2
PG 1        `enter program mode, start program at address 1
LB AA       `label program AA
MR 250000   `move motor 250000 steps in the positive direction
H           `hold program execution until motion completes
H 1000      `hold 1000 milliseconds
MR -250000  `move motor 250000 steps in the negative direction
H           `hold program execution until motion completes
H 1000      `hold 1000 milliseconds
IC LP       `increment user variable LP
PR " LP=",LP; `print axis position, 4 characters used, the
            `terminal will display LP=1 LP=2 LP=3
BR AA, LP<3 `branch to process label AA, if user variable LP< 3
E           `end program execution
PG         `exit program, return to immediate mode
```

4. Type FD in the Terminal Window and press ENTER to clear the MDrive buffer to factory defaults before downloading any program.
5. Click on drop-down menu Transfer > Download to transfer the program from the Program Edit Window to the Terminal Window. (Under “Source Type” choose “Edit Window”.)
6. Type EX 1 in the Terminal Window and press ENTER to execute the program. (EX = Execute at address 1.)
7. The Motion Control MForce MicroDrive will turn the motor 250,000 microsteps in a clockwise direction, accelerating at 100,000 microsteps per sec², then decelerating at 100,000 microsteps per sec², pausing for 1000 milliseconds, then reversing the sequence in a counterclockwise direction, repeating the motion cycle 3 times until the program ends.

N **NOTE:** Entering MForce MicroDrive commands into the Program Edit Window, to be edited and saved, is called “Program Mode”.

N **NOTE:** The program can be stopped by pressing the Escape Button or by pressing Ctrl+C.

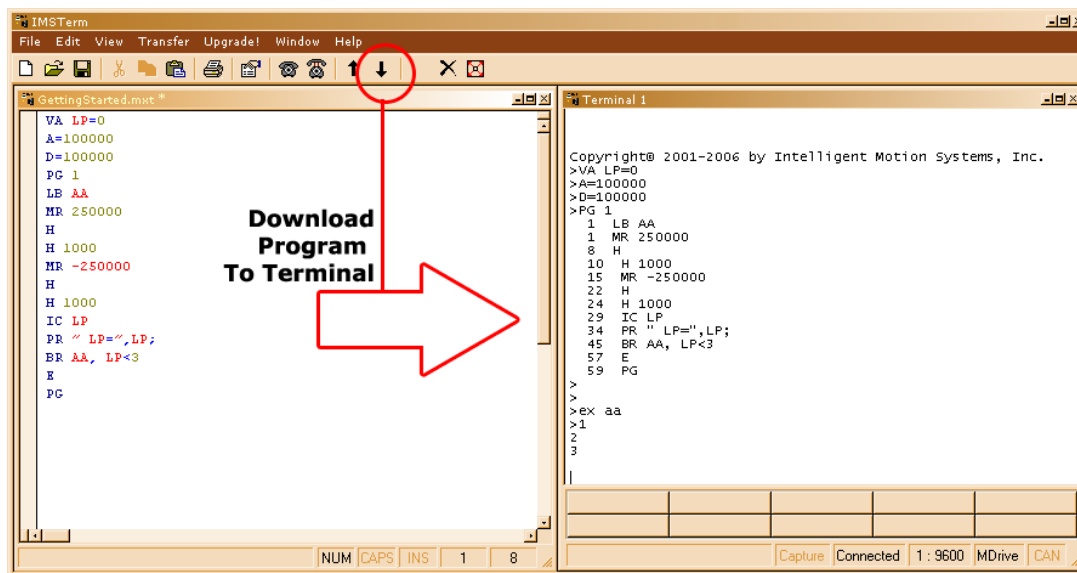

Figure GS.6: Download the Program

Programming Notes

The example above demonstrates basic commands that verify that your Motion Control MForce MicroDrive is communicating with your PC. More complex commands and movement may require that your I/O and/or Analog Input be interfaced and configured. Refer to the Programming and Software Reference for details.

For more information on Programming and Command Control Sets, refer to the Programming and Software Reference Manual available on the your product CD or via the IMS web site at <http://www.imshome.com/manuals.html>.

This Page Intentionally Left Blank



PART 1: HARDWARE SPECIFICATIONS

Section 1.1: Product Introduction

Section 1.2: Standard Specifications

Section 1.3: Expanded Plus² Specifications



Note: The Motion Control MForce MicroDrive is available with CAN communications. For more information see Appendix F.

Introduction

The Motion Control MForce MicroDrive offers system designers a low cost, intelligent motion controller integrated with a +12 to +48 volt/2A RMS Output Current microstepping drive and Motion Controller.

The unsurpassed smoothness and performance delivered by the Motion Control MForce MicroDrive are achieved through IMS's advanced 2nd generation current control. By applying innovative techniques to control current flow through the motor, resonance is significantly dampened over the entire speed range and audible noise is reduced.

The MForce MicroDrive accepts a broad input voltage range from +12 to +48 VDC, delivering enhanced performance and speed. Oversized input capacitors are used to minimize power line surges, reducing problems that can occur with long runs and multiple drive systems. An extended operating range of -40° to +85°C provides long life, trouble free service in demanding environments.

Standard features available in the MForce MicroDrive include four +5 to +24 volt general purpose I/O lines, one 10 bit analog input, 0 to 5MHz step clock rate, 20 microstep resolutions up to 51,200 steps per revolution, and full featured easy-to-program instruction set.

Expanded features in the MForce MicroDrive Plus² version include eight +5 to +24 volt general purpose I/O lines and the capability of electronic gearing by following a rotary or linear axis at an electronically controlled ratio, or an output clock can be generated fixed to the internal step clock.

MForce MicroDrive Plus² models are available with optional closed loop control. This increases functionality by adding stall detection, position maintenance and find index mark. The closed loop configuration offers an expanded choice of line counts and resolutions by interfacing to a remotely mounted user-supplied external encoder.

The Motion Control MForce MicroDrive communicate over RS-422/485 which allows for point-to-point or multiple unit configurations utilizing one communication port. Addressing and hardware support up to 62 uniquely addressed units communicating over a single line. Baud rate is selectable from 4.8 to 115.2kbps.

Power and signal interface connections are accomplished using 12.0" (30.5cm) flying leads or a 7 position terminal strip. Plus² versions interface using a pluggable locking wire crimp connector. Motor phases are connected via a pluggable 4-pin locking wire crimp connector.

The MForce MicroDrive is a compact, powerful and inexpensive solution that will reduce system cost, design and assembly time for a large range of applications.



Figure 1.1.1: MForce MicroDrive With 1-Pin Terminal Strip



Figure 1.1.2: MForce MicroDrive Plus² Wire Crimp

Feature Summary – Standard and Plus² Expanded

Standard Features

- Highly Integrated Microstepping Driver and Motion Controller
- Advanced 2nd Generation Current Control for Exceptional Performance and Smoothness
- Single Supply: +12 to +48 VDC
- Compact Size: 1.7 x 2.3 x 1.3 inches (42 x 59 x 1.3 mm)
- 2A RMS/2.8 A Peak (per phase) Output Current
- Low Cost
- Extremely Compact
- Auxiliary Logic Power Supply Input
- 20 Microstep Resolutions up to 51,200 Steps Per Rev Including: Degrees, Metric, Arc Minutes

- Open or Closed Loop Control
- Programmable Motor Run and Hold Currents
- Four +5 to +24 VDC I/O Lines Accept Sourcing or Sinking Outputs
- One 10 Bit Analog Input Selectable: 0 to +10VDC, 0 to +5VDC, 0-20 mA, 4-20 mA
- 0 to 5MHz Step Clock Rate Selectable in 0.59Hz Increments
- RS-422/485 Communications (Optional CANopen details available at www.imshome.com)
- 62 Software Addresses for Multi-Drop Communications
- Simple 1 to 2 Character Instructions
- Interface Options:
 - 12.0" (30.5cm) Flying Leads
 - 7-Pin Pluggable Terminal

Expanded Features – Available only in the Plus² Version

- +5 to +24 VDC Tolerant Sourcing or Sinking, Inputs and Outputs:
- 8 I/O Points with Electronic Gearing (or)
- 4 I/O Points with External/Remote Encoder for Closed Loop Control
- High Speed Position Capture Input or Trip Output
- Pluggable Locking Wire Crimp Interface

SECTION 1.2

Motion Control MForce MicroDrive Specifications



WARNING!
The maximum +48 VDC Input Voltage of the

MForce MicroDrive series includes motor Back EMF, Power Supply Ripple and High Line.

WARNING! Because the MForce MicroDrive consists of two core components, a drive and a motor, close attention must be paid to the thermal environment where the device is used. See Thermal Specifications.

Standard Electrical Specifications

Electrical Specifications	
Input Voltage (+V) Range*	+12 to +48 VDC
Max Power Supply Current (Per MForce MicroDrive)*	3.2 Amps
Aux-Logic Input Voltage**	+12 to +24 VDC

* Actual Power Supply Current will depend on Voltage and Load.

** Maintains power to control and feedback circuits [only] when input voltage is removed

Output Current	
Output Current RMS	3 Amps
Output Current Peak (Per Phase)	4.2 Amps

Environmental Specifications	
Heat Sink Temperature	-40°C to +85°C

I/O Specifications	
General Purpose I/O - Number and Type	
Plus (I/O Points 1-4)	4 Sourcing or Sinking Inputs or 4 Sinking Outputs
General Purpose I/O - Electrical	
Inputs	TTL up to +24 VDC
Sinking Outputs (All)	Up to +24 VDC
Output Sink Current (Plus)	up to 600 mA (One Channel)
Logic Threshold (Logic 0)	< 0.8 VDC
Logic Threshold (Logic 1)	> 2.2 VDC
Protection (Sinking)	Over Temp, Short Circuit
Protection (Sourcing)	Transient Over Voltage, Inductive Clamp
Analog Input	
Resolution	10 Bit
Range (Voltage Mode)	0 to +5 VDC, 0 to +10 VDC
Range (Current Mode)	4 to 20 mA, 0 to 20mA
Clock I/O	
Types	Step/Direction, Up/Down, Quadrature
Logic Threshold	TTL Input, TTL Output (with 2 kΩ Load to Ground)
Trip Output/Capture Input	
Logic Threshold	TTL Input, TTL Output (with 2 kΩ Load to Ground)

Communications Specifications	
Protocol	RS-422/RS-485
BAUD Rate	4.8k, 9.6k, 19.2k, 38.4k, 115.2 kbps

Motion Specifications

Microstep Resolution - Open Loop

Number of Resolutions	20
-----------------------	----

Available Microsteps Per Revolution									
200	400	800	1000	1600	2000	3200	5000	6400	10000
12800	20000	25000	25600	40000	50000	51200	36000 ¹	21600 ²	25400 ³

1=0.01 deg/ μ step 2=1 arc minute/ μ step 3=0.001 mm/ μ step

Counters

Counter 1 (C1) Type	Position
Counter 2 (C2) Type	Encoder
Resolution	32 Bits
Maximum Edge Rate	5 MHz

Velocity

Range	$\pm 5,000,000$ Steps/Sec.
Resolution	0.5961 Steps/Sec.

Acceleration/Deceleration

Range	1.5×10^9 Steps/Sec. ²
Resolution	90.9 Steps/Sec. ²

* Microstep Resolution must be set to 2x the Encoder Counts/Rev minimum.

Software Specifications

Program Storage Type/Size	Flash/6384 Bytes
User Registers	(4) 32 Bit
User Program Labels and Variables	192
Math, Logic and Conditional Functions	+, -, x, \div , <, >, =, \leq , \geq , AND, OR, XOR, NOT
Branch Functions	Branch and Call (Conditional)
Party Mode Addresses	62
Encoder Functions	Stall Detect, Position Maintenance, Find Index
Predefined I/O Functions	
Input Functions	Home, Limit+, Limit -, Go, Stop, Pause, Jog+, Jog-, Analog Input
Output Functions	Moving, Fault, Stall, Velocity Changing
Trip Functions	Trip on Input, Trip on Position, Trip on Time, Trip Capture

Mechanical Specifications

Dimensions in Inches (mm)

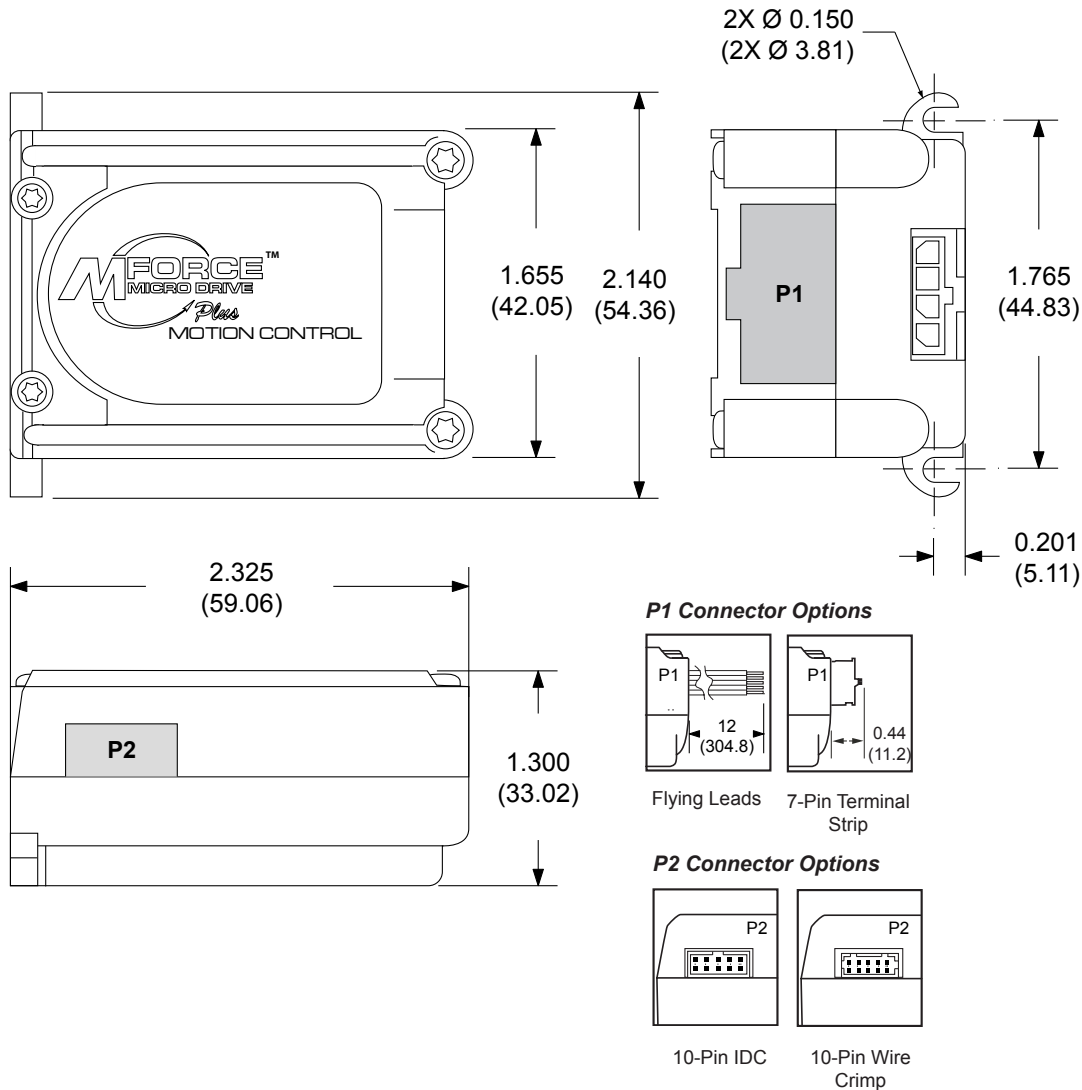

Figure 1.2.1: Mechanical Specifications

Pin/Wire Assignments and Description

P1 Connector - I/O and Power Connections

Flying Lead Wire Color	7-Pin Pluggable Terminal Strip	Function	Description
White/Yellow	Pin 1	I/O 1	0 to +24 VDC Programmable I/O Point 1
White/Orange	Pin 2	I/O 2	0 to +24 VDC Programmable I/O Point 2
White/Violet	Pin 3	I/O 3	0 to +24 VDC Programmable I/O Point 3
White/Blue	Pin 4	I/O 4	0 to +24 VDC Programmable I/O Point 4
Green	Pin 5	AIN	0 to +5 VDC/0 to +10 VDC / 4 to 20 mA / 0 to 20 mA Analog Input
Black	Pin 6	GND	Power and Auxiliary Ground
Red	Pin 7	+V	+12 to +48 VDC Motor Power Supply Input

Table 1.2.1: P1 — Pin Assignment, Power and I/O



WARNING! Because the MForce MicroDrive DOES NOT have a Pin Configuration label on the body of the device please ensure that all wiring connections are cross-checked against these tables and figures.

P1 Connector Options

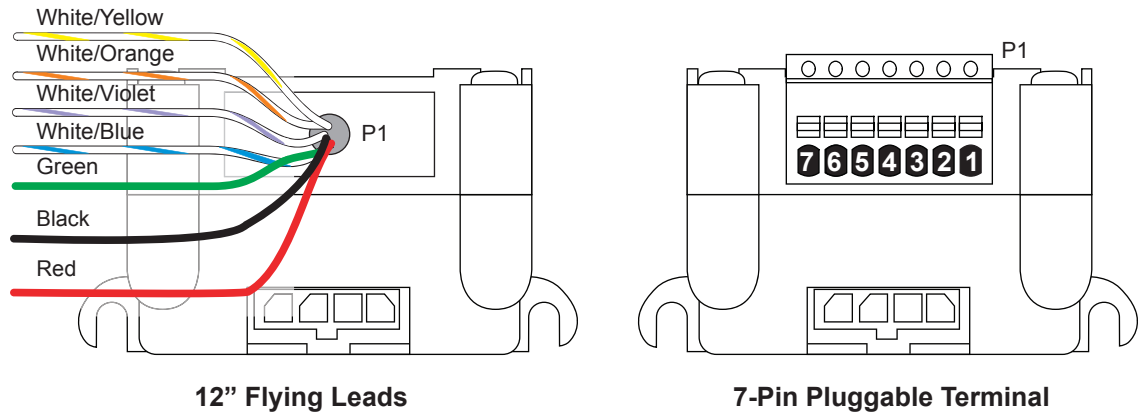

Figure 1.2.2: P1 Wire Color and Pin Assignment



NEED A CABLE?

The following cables and converters are available to interface communications with

P2:

USB to RS-422/485:

MD-CC400-001 (10-pin IDC)
MD-CC402-001 (10-pin Wire Crimp)

Multi-Drop for 10-Pin Wire Crimp Party-Mode

PD10-1434-FL3

P2 Connector - RS-422/485 Communications

Pin Assignment - P2 RS-422/485 Communications			
10-Pin IDC	10-Pin Wire Crimp	Function	Description
Pin 1	Pin 9	TX +	Transmit +: Connects to Receive + of the Communications Host.
Pin 2	Pin 10	TX -	Transmit -: Connects to Receive - of the Communications Host.
Pin 3	Pin 7	RX +	Receive +: Connects to Transmit + of the Communications Host.
Pin 4	Pin 8	RX -	Receive -: Connects to Transmit - of the Communications Host.
Pin 5	Pin 5	Aux-Logic	+12 to +24 VDC Auxiliary Logic Supply Input. This provides power to control and logic circuits if main power is removed.
Pin 6	Pin 6	RX +	Receive +: This point will typically be used to connect to RX+ (Pin 3/7*) of a second MDrivePlus for Multidrop Communications.
Pin 7	Pin 3	RX -	Receive -: This point will typically be used to connect to RX - (Pin 4/8*) of a second MDrivePlus for Multidrop Communications.
Pin 8	Pin 4	TX -	Transmit -: This point will typically be used to connect to TX - (Pin 1/9*) of a second MDrivePlus for Multidrop Communications.
Pin 9	Pin 1	TX +	Transmit +: This point will typically be used to connect to TX + (Pin 2/10*) of a second MDrivePlus for Multidrop Communications.
Pin 10	Pin 2	COMM GND	Communications Ground. This Ground is ONLY to be used to ground communications. Auxiliary Logic Supply must be grounded at the motor supply ground.
Recommended Converter/Cable	Recommended Converter/Cable	* For multi-drop communications systems IMS offers the PD10-1434-FL3 Prototype Development Cable. See Cables and Cordsets in the Appendices for more details.	
MD-CC400-001	MD-CC402-001		

Table 1.2.2: P2 — Pin Assignment, RS-422/485 Communications

P2 Connector Options

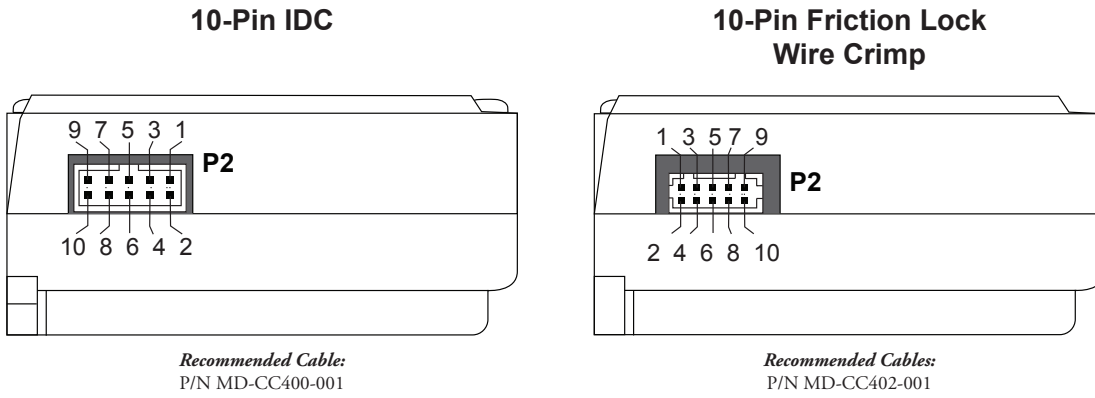

Figure 1.2.3: P2 Pin Assignment

P3 Connector - Motor Phase Connector

4-Pin Wire Crimp	Function	Description
Pin 1	$\bar{\emptyset}A$	Phase A of the Motor
Pin 2	$\emptyset A$	Phase A of the Motor
Pin 3	$\bar{\emptyset}B$	Phase B of the Motor
Pin 4	$\emptyset B$	Phase B of the Motor

Table 1.2.3: P3 — Pin Assignment, Motor Phase Connections

P3 Connector

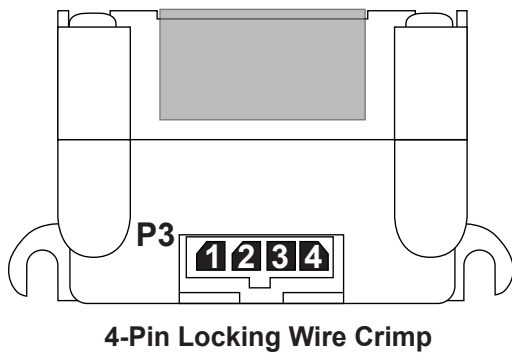

Recommended Cable: P/N PD04-MF17-FL3

Recommended Connector Shell and Pins

Shell: AMP 1445022-4

Pins: AMP 1-794610-2

Wire: 20 AWG Shielded Twisted Pair



WARNING!
Ensure proper connection of the motor phases prior to power application!

Figure 1.2.4: P3 — 4-Pin Locking Wire Crimp Motor Connector

Accessories

Motors and Encoders

IMS offers a wide range of motors, encoders and accessories recommended for interface with the Motion Control MForce MicroDrive. For complete specifications on these products, please visit the IMS web site at www.imshome.com. See Appendix C for Encoder information and Appendix E for Motor details.

Power Supplies

IMS recommends the following power supplies for operating the MForce MicroDrive: ISP402, ISP404, ISP200-4. For complete power supply specifications, visit the IMS web site at www.imshome.com. See Appendix A for recommended IMS power supplies.

Connectivity

QuickStart Kit

For rapid design verification, all-inclusive QuickStart Kits have communication converter, prototype development cable(s), instructions

Communication Converter Cables

These convenient 12.0' (3.6m) accessory cables connect a PC's USB Port to the MForce MicroDrive P2 Connector. An electrically isolated, in-line RS-422 converter enables communications and programming to a single MForce MicroDriveMotion Control. Cable purchase recommended with first orders. Versions include:

USB to 10-Pin IDC	Part No. MD-CC401-001
USB to 10-Pin Wire Crimp	Part No. MD-CC402-001
Cable Assembly for Party-Mode	Part No. PD10-1434-FL3

Mating Connector Kits

Use to build your own cables. Kit contains 5 mating shells with pins. Cable not supplied. Manufacturer's crimp tool recommended.

Mates to connector:

10-Pin Wire Crimp	CK-02
4-Pin Wire Crimp	CK-06

Kit contains 5 mating connectors that press fit onto ribbon cable. Cable not supplied.

10-Pin IDC	CK-01
------------------	-------

Prototype Development Cables

To speed prototyping, these 10' (3m) cables are available:

Motor Interface: 4-pin Wire Crimp Cable	PD04-MF17-FL3
---	---------------

See Appendix D: Connectivity for details.

SECTION 1.3

MForce MicroDrive Plus² Expanded Specifications

Plus² Electrical Specifications

Electrical Specifications	
Input Voltage (+V) Range*	+12 to +48 VDC
Max Power Supply Current (Per MDrive17Plus)*	3.2 Amps
Aux-Logic Input Voltage**	+12 to +24 VDC

* Actual Power Supply Current will depend on Voltage and Load.

** Maintains power to control and feedback circuits [only] when input voltage is removed

Output Current	
Output Current RMS	3 Amps
Output Current Peak (Per Phase)	4.2 Amps

Environmental Specifications	
Heat Sink Temperature	-40°C to +85°C

I/O Specifications	
General Purpose I/O - Number and Type	
Plus (I/O Points 1-4)	4 Sourcing or Sinking Inputs or 4 Sinking Outputs
Plus ² (I/O Points 1-4, 9-12)	8 Sourcing or Sinking Inputs or 8 Sourcing or Sinking Outputs (2 Banks of 4 Each)
General Purpose I/O - Electrical	
Inputs	TTL up to +24 VDC
Sinking Outputs (All)	Up to +24 VDC
Sourcing Outputs (Plus ²)	+12 to +24 VDC
Output Sink Current (Plus)	up to 600 mA (One Channel)
Output Sink Current (Plus ²)	up to 600 mA (One Channel in each I/O Bank)
Logic Threshold (Logic 0)	< 0.8 VDC
Logic Threshold (Logic 1)	> 2.2 VDC
Protection (Sinking)	Over Temp, Short Circuit
Protection (Sourcing)	Transient Over Voltage, Inductive Clamp
Analog Input	
Resolution	10 Bit
Range (Voltage Mode)	0 to +5 VDC, 0 to +10 VDC
Range (Current Mode)	4 to 20 mA, 0 to 20mA
Clock I/O	
Types	Step/Direction, Up/Down, Quadrature
Logic Threshold	TTL Input, TTL Output (with 2 kΩ Load to Ground)
Trip Output/Capture Input	
Logic Threshold	TTL Input, TTL Output (with 2 kΩ Load to Ground)

Communications Specifications	
Protocol	RS-422/RS-485
BAUD Rate	4.8k, 9.6k, 19.2k, 38.4k, 115.2 kbps

Motion Specifications

Microstep Resolution - Open Loop

Number of Resolutions	20
-----------------------	----

Available Microsteps Per Revolution									
200	400	800	1000	1600	2000	3200	5000	6400	10000
12800	20000	25000	25600	40000	50000	51200	36000 ¹	21600 ²	25400 ³

1=0.01 deg/μstep 2=1 arc minute/μstep 3=0.001 mm/μstep

Optional Remote Encoder (Plus² Only)‡

Type	User Defined Differential
Steps Per Revolution	See Microstep Resolution - Open Loop
Resolution	User Defined*
Counters	
Counter 1 (C1) Type	Position
Counter 2 (C2) Type	Encoder
Resolution	32 Bits
Maximum Edge Rate	5 MHz
Velocity	
Range	±5,000,000 Steps/Sec.
Resolution	0.5961 Steps/Sec.
Acceleration/Deceleration	
Range	1.5 x 10 ⁹ Steps/Sec. ²
Resolution	90.9 Steps/Sec. ²
Electronic Gearing (Plus² Only)	
Range (Ratio)	0.001 to 2.000
Resolution	32 Bits
Voltage	+5 VDC Logic Level
Input Filter Range	50 nS to 12.9 μS
Secondary Output Clock Range	1 to 1
High Speed I/O (Plus² Only)	
Position Capture Input - Resolution	32 Bits
Position Capture Input - Filtering	50 nS to 12.9 μS
Trip Output - Speed	150 nS
Trip Output - Resolution	32 Bits
Trip Output Voltage	+5 VDC Logic Level

* Microstep Resolution must be set to 2x the Encoder Counts/Rev minimum.

‡With Optional Remote Encoder the Encoder Inputs replace I/O Points 9-12 and the Step/Direction Clock I/O Points.

Software Specifications	
Program Storage Type/Size	Flash/6384 Bytes
User Registers	(4) 32 Bit
User Program Labels and Variables	192
Math, Logic and Conditional Functions	+, -, x, ÷, <, >, =, ≤, ≥, AND, OR, XOR, NOT
Branch Functions	Branch and Call (Conditional)
Party Mode Addresses	62
Encoder Functions	Stall Detect, Position Maintenance, Find Index
Predefined I/O Functions	
Input Functions	Home, Limit+, Limit -, Go, Stop, Pause, Jog+, Jog-, Analog Input
Output Functions	Moving, Fault, Stall, Velocity Changing
Trip Functions	Trip on Input, Trip on Position, Trip on Time, Trip Capture

Mechanical Specifications

Dimensions in Inches (mm)

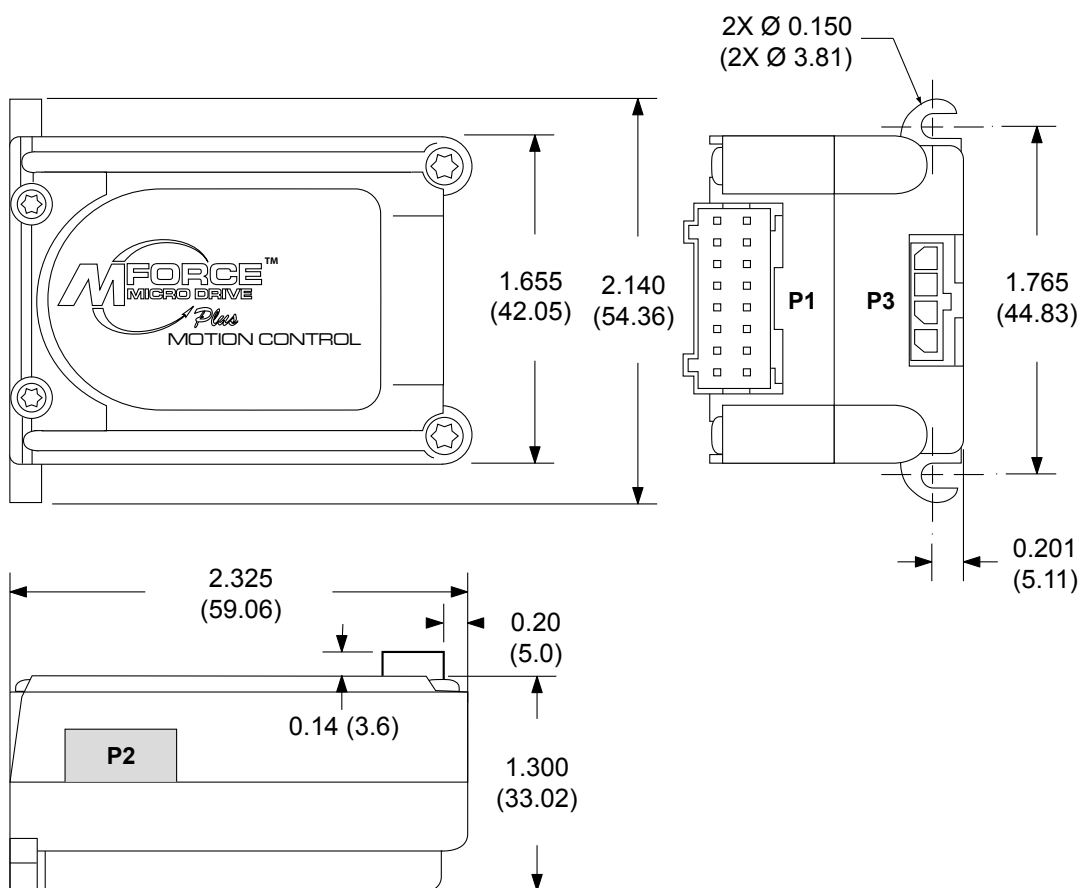

Figure 1.3.1: Mechanical Specifications

Pin Assignments and Description

P1 Connector - Power and Expanded I/O Configuration

P1 - Expanded I/O Configuration		
16-Pin Wire Crimp	Function	Description
Pin 1	I/O PWR	I/O Power, used with sourcing inputs or outputs. See Section 2.3 for more details.
Pin 2	I/O GND	Non-isolated I/O Ground. Common with Power Ground.
Pin 3	I/O 1	0 to +24 VDC Programmable I/O Point 1
Pin 4	I/O 2	0 to +24 VDC Programmable I/O Point 2
Pin 5	I/O 3	0 to +24 VDC Programmable I/O Point 3
Pin 6	I/O 4	0 to +24 VDC Programmable I/O Point 4
Pin 7	I/O 9	0 to +24 VDC Programmable I/O Point 9
Pin 8	I/O 10	0 to +24 VDC Programmable I/O Point 10
Pin 9	I/O 11	0 to +24 VDC Programmable I/O Point 11
Pin 10	I/O 12	0 to +24 VDC Programmable I/O Point 12
Pin 11	Capture/Trip I/O	High Speed Capture Input or Trip Output. +5 VDC Logic Level.
Pin 12	AIN	0 to 10 V / 4 to 20 mA / 0 to 20 mA Analog Input.
Pin 13	SCLK	Step Clock I/O. Can also be configured as Quadrature or Clock Up/Down.
Pin 14	DIR	Direction I/O. Can also be configured as Quadrature or Clock Up/Down.
Pin 15	+V	+12 to +48 VDC Motor Power Supply Input.
Pin 16	GND	Power and Auxiliary Ground
Recommended Cable		
PD16-1417-FL3		

Table 1.3.1: P1 — Pin Assignment, Expanded I/O Configuration

P1 Connector - Power and I/O with Remote Encoder Configuration

P1 - Expanded I/O Configuration		
16-Pin Wire Crimp	Function	Description
Pin 1	I/O PWR	I/O Power, used with sourcing inputs or outputs. See Section 2.3 for more details.
Pin 2	I/O GND	Non-isolated I/O Ground. Common with Power Ground.
Pin 3	I/O 1	0 to +24 VDC Programmable I/O Point 1
Pin 4	I/O 2	0 to +24 VDC Programmable I/O Point 2
Pin 5	I/O 3	0 to +24 VDC Programmable I/O Point 3
Pin 6	I/O 4	0 to +24 VDC Programmable I/O Point 4
Pin 7	Channel A +	Encoder Channel Channel A + Input.
Pin 8	Channel A –	Encoder Channel Channel A – Input.
Pin 9	Channel B +	Encoder Channel Channel B + Input.
Pin 10	Channel B –	Encoder Channel Channel B – Input.
Pin 11	Capture/Trip I/O	High Speed Capture Input or Trip Output. +5 VDC Logic Level.
Pin 12	AIN	0 to 10 V / 4 to 20 mA / 0 to 20 mA Analog Input.
Pin 13	Index +	Encoder Index + Input.
Pin 14	Index –	Encoder Index – Input.
Pin 15	+V	+12 to +48 VDC Motor Power Supply Input.
Pin 16	GND	Power and Auxiliary Ground
Recommended Cable		
PD16-1417-FL3		

Table 1.3.2: P1 — Pin Assignment, Remote Encoder Configuration

P1 Connector

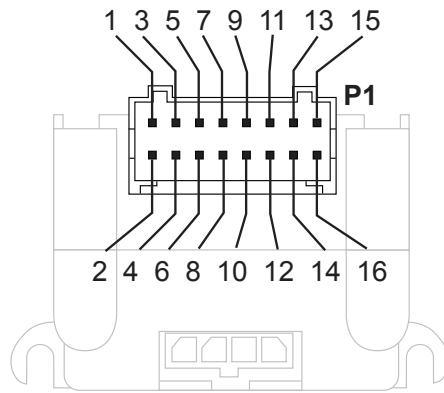

Figure 1.3.2: 16-Pin Wire Crimp Connector P1 Pin Numbers

P2 Connector - RS-422/485 Communications

Pin Assignment - P2 RS-422/485 Communications			
10-Pin IDC	10-Pin Wire Crimp	Function	Description
Pin 1	Pin 9	TX +	Transmit +: Connects to Receive + of the Communications Host.
Pin 2	Pin 10	TX -	Transmit -: Connects to Receive - of the Communications Host.
Pin 3	Pin 7	RX +	Receive +: Connects to Transmit + of the Communications Host.
Pin 4	Pin 8	RX -	Receive -: Connects to Transmit - of the Communications Host.
Pin 5	Pin 5	Aux-Logic	+12 to +24 VDC Auxiliary Logic Supply Input. This provides power to control and logic circuits if main power is removed.
Pin 6	Pin 6	RX +	Receive +: This point will typically be used to connect to RX+ (Pin 3/7*) of a second MDrivePlus for Multidrop Communications.
Pin 7	Pin 3	RX -	Receive -: This point will typically be used to connect to RX - (Pin 4/8*) of a second MDrivePlus for Multidrop Communications.
Pin 8	Pin 4	TX -	Transmit -: This point will typically be used to connect to TX - (Pin 1/9*) of a second MDrivePlus for Multidrop Communications.
Pin 9	Pin 1	TX +	Transmit +: This point will typically be used to connect to TX + (Pin 2/10*) of a second MDrivePlus for Multidrop Communications.
Pin 10	Pin 2	COMM GND	Communications Ground. This Ground is ONLY to be used to ground communications. Auxiliary Logic Supply must be grounded at the motor supply ground.
Recommended Converter/Cable	Recommended Converter/Cable	* For multi-drop communications systems IMS offers the PD10-1434-FL3 Prototype Development Cable. See Cables and Cordsets in the Appendices for more details.	
MD-CC400-001	MD-CC402-001		

Table 1.3.3: P2 — Pin Assignment, RS-422/485 Communications

P2 Connector Options

10-Pin IDC

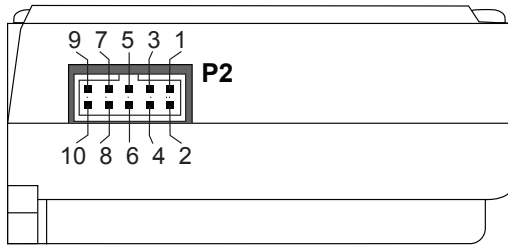

Recommended Cable:
P/N MD-CC400-001

10-Pin Friction Lock Wire Crimp

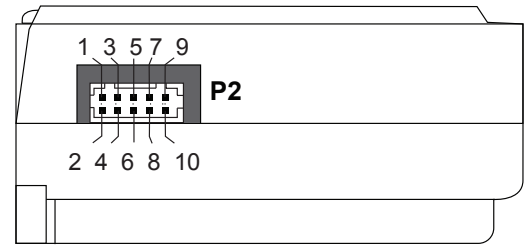

Recommended Cables:
P/N MD-CC402-001

Figure 1.3.3: P2 Pin Assignment



WARNING!
Ensure proper connection of the motor phases prior to power application!

P3 Connector - Motor Phase Connector

Pin Assignment - P3 Motor		
4-Pin Wire Crimp	Function	Description
Pin 1	$\bar{\emptyset}A$	Phase A of the Motor
Pin 2	$\emptyset A$	Phase A of the Motor
Pin 3	$\bar{\emptyset}B$	Phase B of the Motor
Pin 4	$\emptyset B$	Phase B of the Motor

Table 1.3.4: P3 — Pin Assignment, Motor Phase Connections

Recommended Cable: P/N PD04-MF17-FL3

Recommended Connector Shell and Pins

Shell: AMP 1445022-4

Pins: AMP 1-794610-2

Wire: 20 AWG Shielded Twisted Pair

P3 Connector

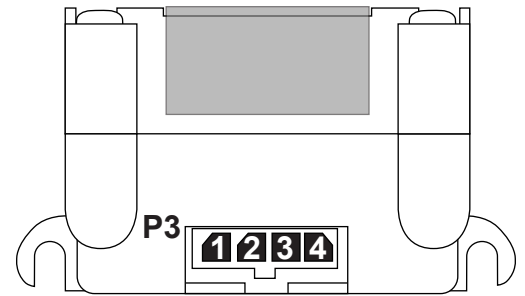

4-Pin Locking Wire Crimp

Figure 1.3.4: P3: 4-Pin Locking Wire Crimp Motor Connector

Accessories

Motors and Encoders

IMS offers a wide range of motors, encoders and accessories recommended for interface with the Motion Control MForce MicroDrive. For complete specifications on these products, please visit the IMS web site at www.imshome.com. See Appendix C for Encoder information and Appendix E for Motor details.

Power Supplies

IMS recommends the following power supplies for operating the MForce MicroDrive: ISP402, ISP404, ISP200-4. For complete power supply specifications, visit the IMS web site at www.imshome.com. See Appendix A for recommended IMS power supplies.

Connectivity

See Appendix D: Connectivity, for more details on Communications Converters, Prototype Development Cables and Mating Connector Kits.

QuickStart Kit

For rapid design verification, all-inclusive QuickStart Kits have communication converter, prototype development cable(s), instructions

Communication Converter Cables

These convenient 12.0' (3.6m) accessory cables connect a PC's USB Port to the MForce MicroDrive P2 Connector. An electrically isolated, in-line RS-422 converter enables parameter setting to a single MForce MicroDrive Motion Control. Cable purchase recommended with first orders. Versions include:

USB to 10-Pin IDC	Part No. MD-CC400-001
USB to 10-Pin Wire Crimp	Part No. MD-CC402-001
Cable Assembly for Party-Mode	Part No. PD10-1434-FL3

Prototype Development Cable

To speed prototyping of Plus² versions, IMS recommends the following 10' (3m) interface cable with first orders:

2-pin Wire Crimp Cable	Part No. PD02-2300-FL3
14-pin Wire Crimp Cable	Part No. PD16-1417-FL3

Mating Connector Kits

Use to build your own cables. Kit contains 5 mating shells with pins. Cable not supplied. Manufacturer's crimp tool recommended.

Mates to connector:

10-Pin Wire Crimp	CK-02
14-Pin Wire Crimp	CK-09
2-Pin Wire Crimp	CK-04
4-Pin Wire Crimp	CK-06

Kit contains 5 mating connectors that press fit onto ribbon cable. Cable not supplied.

10-Pin IDC	CK-01
------------------	-------



PART 2: CONNECTING AND INTERFACING

Section 2.1: Mounting and Connection Recommendations

Section 2.2: Interfacing DC Power and Auxiliary Logic

Section 2.3: Motor Sizing and Selection

Section 2.4: Interfacing Communications

Section 2.5: Interfacing and Using the MForce I/O

This Page Intentionally Left Blank

SECTION 2.1

Mounting and Connection Recommendations

Mounting Recommendations

CAUTION

THERMAL MANAGEMENT

Do not remove the thermal pad attached to the mounting surface of the MicroDrive. It is essential to maintaining a safe driver temperature at full current.

Failure to follow these instructions can result in equipment damage.

Flange mounting holes are drilled through with a diameter of 0.150" (3.81mm) to take standard 6X32 (M3 Metric) screws. The length of the screw used will be determined by the mounting flange width. See Mechanical Specifications for mounting hole pattern.

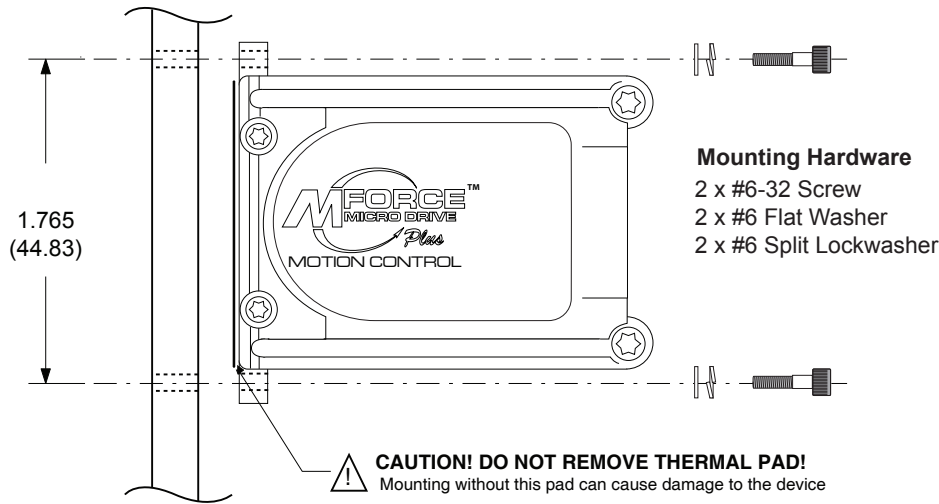

Figure 2.1.1: MForce MicroDrive Mounting Recommendations

DC Power Recommendations

The power requirements for the MForce MicroDrive are:

- Output Voltage +12 to +48 VDC
 - Current (max. per unit) 2 Amps
- (Actual power supply current requirement will depend upon voltage and load)*

Layout and Interface Guidelines

Logic level cables must not run parallel to power cables. Power cables will introduce noise into the logic level cables and make your system unreliable.

Logic level cables must be shielded to reduce the chance of EMI induced noise. The shield needs to be grounded at the signal source to earth. The other end of the shield must not be tied to anything, but allowed to float. This allows the shield to act as a drain.

Power supply leads to the MForce MicroDrive need to be twisted. If more than one driver is to be connected to the same power supply, run separate power and ground leads from the supply to each driver.

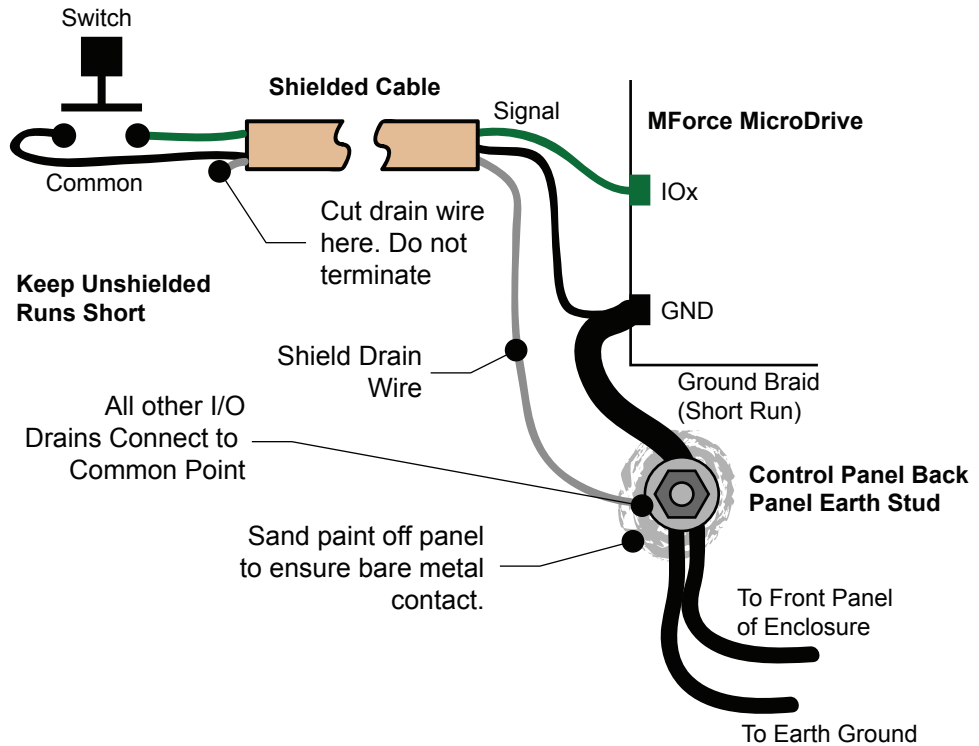

Figure 2.1.2: Grounding and Shielding for Logic Connections

Rules of Wiring

- Power Supply and Motor wiring should be shielded twisted pairs, and run separately from signal-carrying wires.
- A minimum of one twist per inch is recommended.
- Motor wiring should be shielded twisted pairs using 20 gauge, or for distances of more than 5 feet, 18 gauge or better.
- Power ground return should be as short as possible to established ground.
- Power supply wiring should be shielded twisted pairs of 18 gauge for less than 4 amps DC and 16 gauge for more than 4 amps DC.

Rules of Shielding

- The shield must be tied to zero-signal reference potential. It is necessary that the signal be earthed or grounded, for the shield to become earthed or grounded. Earthing or grounding the shield is not effective if the signal is not earthed or grounded.
- Do not assume that Earth ground is a true Earth ground. Depending on the distance from the main power cabinet, it may be necessary to sink a ground rod at the critical location.
- The shield must be connected so that shield currents drain to signal-earth connections.
- The number of separate shields required in a system is equal to the number of independent signals being processed plus one for each power entrance.
- The shield should be tied to a single point to prevent ground loops.
- A second shield can be used over the primary shield; however, the second shield is tied to ground at both ends.

Securing Power Leads and Logic Leads

Some applications may require that the MForce move with the axis motion. If this is a requirement of your application, the motor leads must be properly anchored. This will prevent flexing and tugging which can cause damage at critical connection points within the MForce.

Recommended Wiring

The following wiring/cabling is recommended for use with the MForce MicroDrive:

Logic Wiring	22 AWG
Wire Strip Length	0.25" (6.0 mm)
Power and Ground	See Section 2.2

Recommended Mating Connectors and Pins

The recommended connector shells and pins are available from IMS as a kit consisting of five (5) connector shells and crimp pins (if required) to construct 5 cable-ends. Also available are communications converters and Prototype Development cables to aid in rapid design and prototyping. These connector kits and cables are detailed in Appendix E of this document.

Communications

Press-Fit IDC - P2

Mating Connector Kit.....	CK-01
Communications Converter.....	MD-CC400-001

Manufacturer PNs

10-Pin IDC	Samtec: TCSD-05-01-N
Ribbon Cable	Tyco: 1-57051-9

Friction Lock Wire Crimp - P2

Mating Connector Kit.....	CK-02
Communications Converter.....	MD-CC402-001

Manufacturer PNs

10-pin Friction Lock	Hirose DF11-10DS-2C
Crimp Contact for 10-pin Friction Lock (22 AWG).....	DF11-22SC
Crimp Contact for 10-pin Friction Lock (24 - 28 AWG)	DF11-2428SC
Crimp Contact for 10-pin Friction Lock (30 AWG).....	DF11-30SC

I/O, Power and Remote Encoder

The following mating connectors are recommended for the MForce34Plus² Units ONLY! Please contact a JST distributor for ordering and pricing information.

Enhanced I/O - P1

Mating Connector Kit.....	CK-10
Prototype Development Cable	PD16-1417-FL3

Manufacturer PNs

14-pin Locking Wire Crimp Connector Shell	JST PN PADP-16V-1-S
Crimp Pins.....	JST PN SPH-001T-P0.5L
Recommended Crimp Tool.....	JST PN YHT2262

Motor

The following mating connectors are recommended for the MForce34Plus² Units ONLY! Please contact a JST distributor for ordering and pricing information.

Enhanced I/O - P1

Mating Connector Kit.....	CK-06
Prototype Development Cable	PD04-MF17-FL3

Manufacturer PNs

4-pin Locking Wire Crimp Connector Shell	Tyco PN 1445022-4
Crimp Pins.....	Tyco PN 1-794610-1
Recommended Crimp Tool.....	Tyco PN 91501-1

This Page Intentionally Left Blank

SECTION 2.2

Interfacing DC Power and Auxiliary Logic

Choosing a Power Supply for Your MForce MicroDrive

When choosing a power supply for your MForce MicroDrive there are performance and sizing issues that must be addressed. An undersized power supply can lead to poor performance and even possible damage to the device, which can be both time consuming and expensive. However, The design of the MForce MicroDrive is quite efficient and may not require as large a supply as you might suspect.

Motors have windings that are electrically just inductors, and with inductors comes resistance and inductance. Winding resistance and inductance result in a L/R time constant that resists the change in current. It requires five time constants to reach nominal current. To effectively manipulate the di/dt or the rate of change, the voltage applied is increased. When traveling at high speeds there is less time between steps to reach current. The point where the rate of commutation does not allow the driver to reach full current is referred to as Voltage Mode. Ideally you want to be in Current Mode, which is when the drive is achieving the desired current between steps. Simply stated, a higher voltage will decrease the time it takes to charge the coil, and therefore will allow for higher torque at higher speeds.

Another characteristic of all motors is Back EMF, and though nothing can be done about back EMF, we can give a path of low impedance by supplying enough output capacitance. Back EMF is a source of current that can push the output of a power supply beyond the maximum operating voltage of the driver and as a result could damage the MForce MicroDrive over time.

The MForce MicroDrive is very current efficient as far as the power supply is concerned. Once the motor has charged one or both windings of the motor, all the power supply has to do is replace losses in the system. The charged winding acts as an energy storage in that the current will re-circulate within the bridge, and in and out of each phase reservoir. While one phase is in the decaying stage of the variable chopping oscillator, the other phase is in the charging stage, this results in a less than expected current draw on the supply.

The MForce MicroDrive is designed with the intention that a user's power supply output will ramp up to greater or equal to the minimum operating voltage. The initial current surge is quite substantial and could damage the driver if the supply is undersized. If a power supply is undersized, upon a current surge the supply could fall below the operating range of the driver. This could cause the power supply to start oscillating in and out of the voltage range of the driver and result in damaging either the supply, driver or both. There are two types of supplies commonly used, regulated and unregulated, both of which can be switching or linear. All have their advantages and disadvantages.

An unregulated linear supply is less expensive and more resilient to current surges, however, voltage decreases with increasing current draw. This can cause serious problems if the voltage drops below the working range of the drive. Also of concern is the fluctuations in line voltage. This can cause the unregulated linear supply to be above or below the anticipated voltage.

A regulated supply maintains a stable output voltage, which is good for high speed performance. They are also not bothered by line fluctuations, however, they are more expensive. Depending on the current regulation, a regulated supply may crowbar or current clamp and lead to an oscillation that as previously stated can lead to damage. Back EMF can cause problems for regulated supplies as well. The current regeneration may be too large for the regulated supply to absorb and may lead to an over voltage condition.

Switching supplies are typically regulated and require little real-estate, which makes them attractive. However, their output response time is slow, making them ineffective for inductive loads. IMS has designed a series of low cost miniature non-regulated switchers that can handle the extreme varying load conditions which makes them ideal for the MForce MicroDrive.

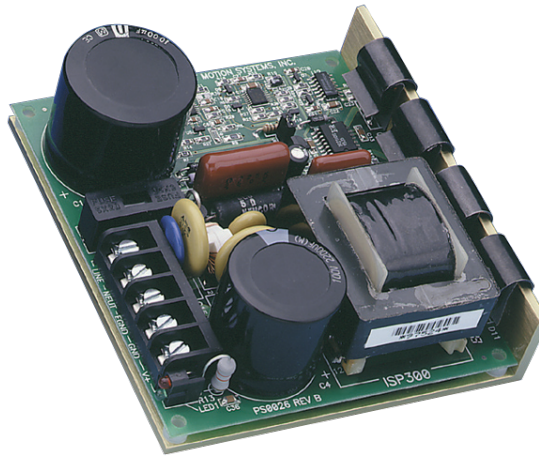

Figure 2.2.1: IMS ISP300 Switch Mode Power Supply

DC Power Supply Recommendations

The power requirements for the MForce MicroDrive are:

MForce MicroDrive

Output Voltage+12 to +48 VDC (Includes Back EMF)
 Current (max. per unit)2A
(Actual power supply current requirement will depend upon voltage and load)

Recommended IMS Power Supplies

IMS unregulated linear and unregulated switching power supplies are the best fit for IMS drive products.

IP402 Unregulated Linear Supply

Input Range

120 VAC Versions102-132 VAC
 240 VAC Versions204-264 VAC

Output (All Measurements were taken at 25 °C, 120 VAC, 60 Hz)

No Load Output Voltage.....39 VDC @ 0 Amps
 Continuous Output Rating.....30 VDC @ 1.0 Amps
 Peak Output Rating.....25 VDC @ 2.0 Amps

ISP200-4 Unregulated Switching Supply

Input Range

120 VAC Versions102-132 VAC
 240 VAC Versions204-264 VAC

Output (All Measurements were taken at 25 °C, 120 VAC, 60 Hz)

No Load Output Voltage.....41 VDC @ 0 Amps
 Continuous Output Rating.....38 VDC @ 1.5 Amps
 Peak Output Rating.....35 VDC @ 3 Amps

Connecting DC Power

Connect the DC Power Supply to your MForce MicroDrive in accordance with the following illustrations.

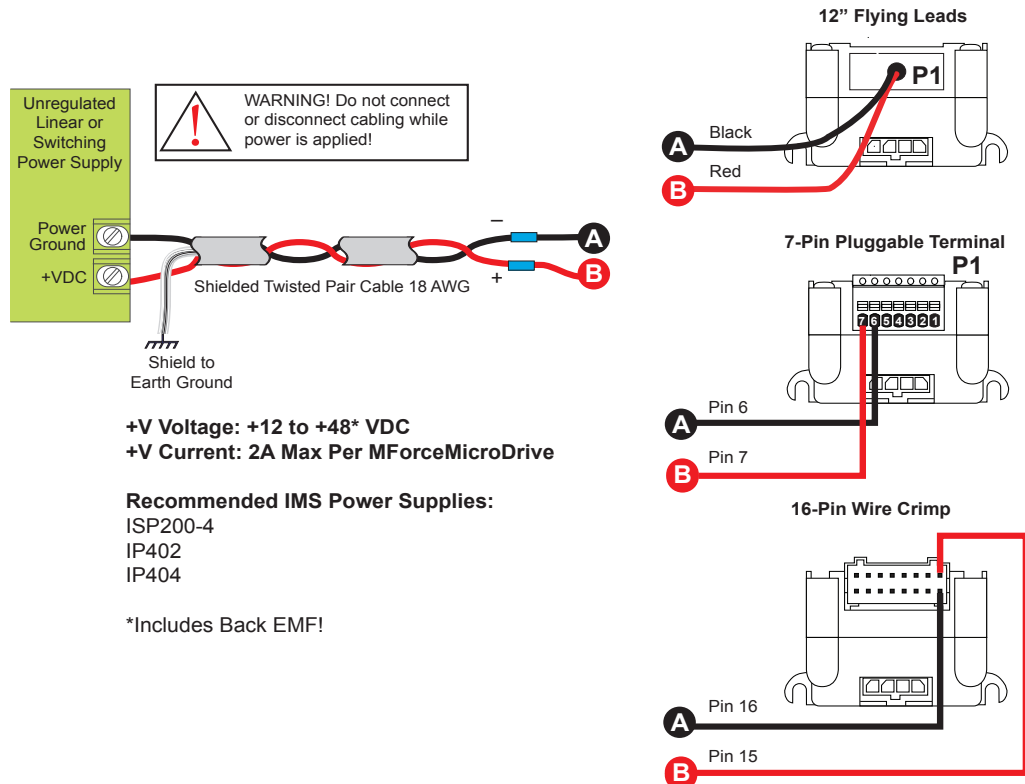

Figure 2.2.3: MForce MicroDrive Power Connections

Recommended Power and Cable Configurations

Cable length, wire gauge and power conditioning devices play a major role in the performance of your MForce.

Example A demonstrates the recommended cable configuration for DC power supply cabling under 50 feet long. If cabling of 50 feet or longer is required, the additional length may be gained by adding an AC power supply cable (see Examples B & C).

Correct AWG wire size is determined by the current requirement plus cable length. Please see the MForce Supply Cable AWG Table at the end of this Appendix.

Example A – Cabling Under 50 Feet, DC Power

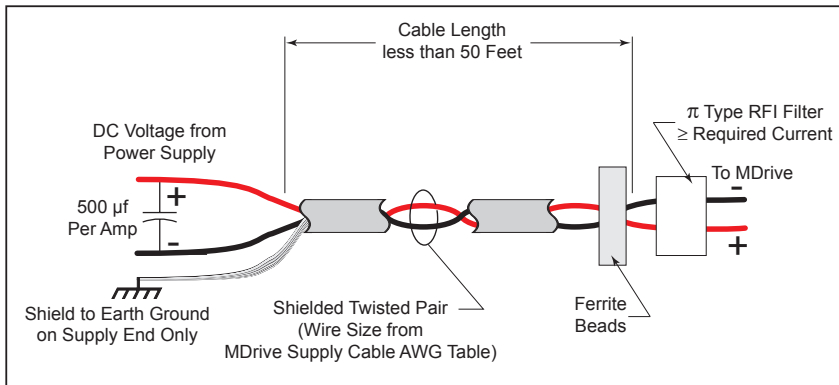

Figure 2.2.4: DC Cabling - Under 50 Feet

Example B – Cabling 50 Feet or Greater, AC Power to Full Wave Bridge

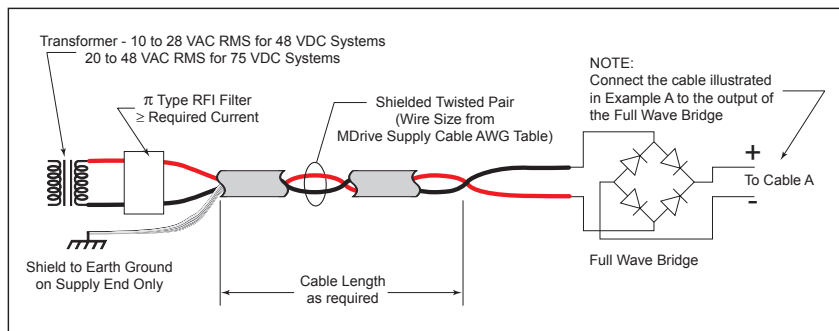

Figure 2.2.5: DC Cabling - 50 Feet or Greater - AC To Full Wave Bridge Rectifier

Example C – Cabling 50 Feet or Greater, AC Power to Power Supply

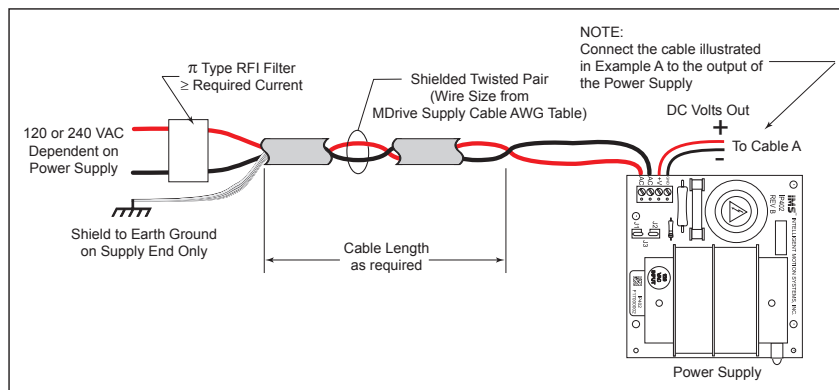

Figure 2.2.6: AC Cabling - 50 Feet or Greater - AC To Power Supply

Recommended Power Supply Cabling

MForce MicroDrive Supply Cable AWG Table					
1 Ampere (Peak)					
Length (Feet)	10	25	50*	75*	100*
Minimum AWG	20	20	18	18	16
2 Amperes (Peak)					
Length (Feet)	10	25	50*	75*	100*
Minimum AWG	20	18	16	14	14

*Use the alternative methods illustrated in examples B and C when cable length is ≥ 50 feet. Also, use the same current rating when the alternate AC power is used.

Table 2.2.1: Recommended Supply Cables

Aux-Logic Supply Connection

The Auxiliary Logic input will maintain power to the Logic circuitry in the absence of motor power. The user will still be able to communicate with the device, however motion commands will be ignored and the internal counter will update by the number of pulses commanded. If stall detection is enabled a stall will register.

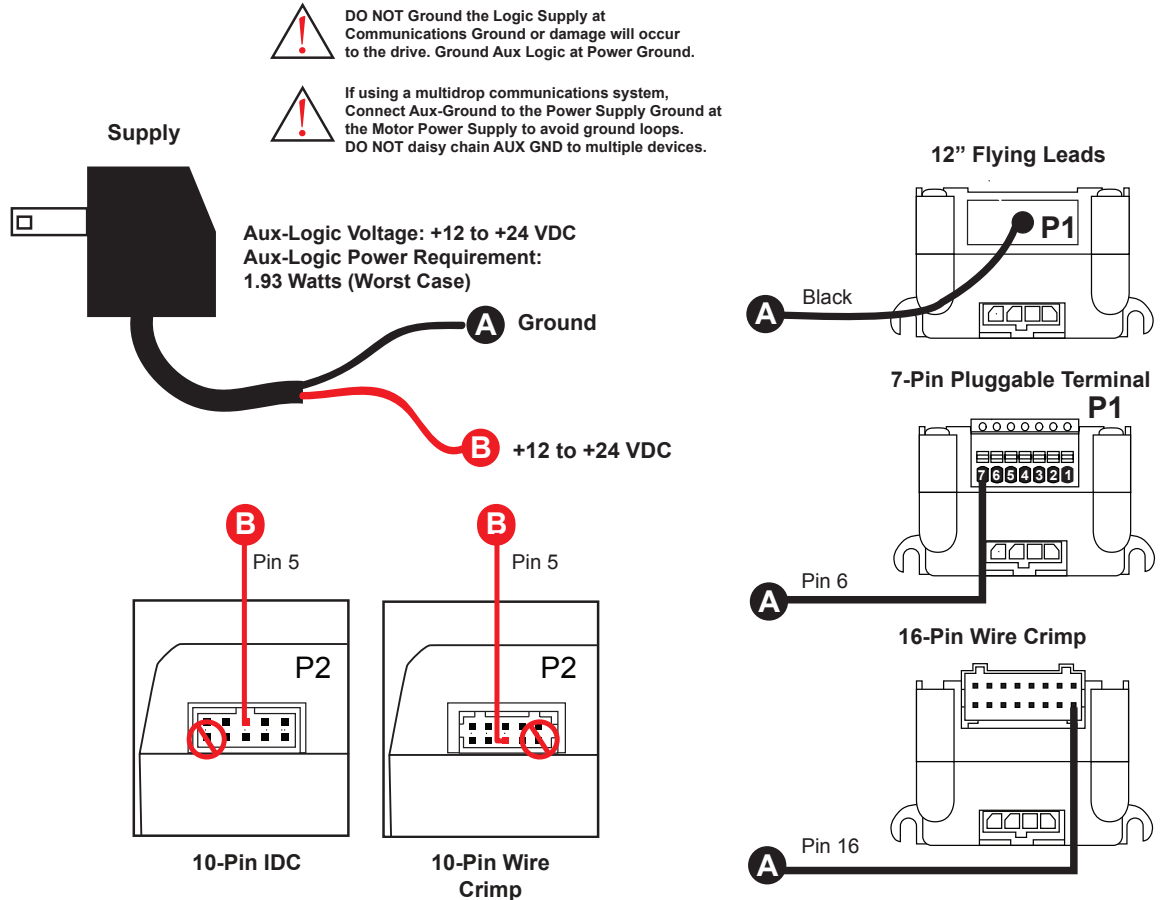

Figure 2.2.7: Aux-Logic Connection

Selecting a Motor

When selecting a stepper motor for your application, there are several factors that need to be taken into consideration:

- How will the motor be coupled to the load?
- How much torque is required to move the load?
- How fast does the load need to move or accelerate?
- What degree of accuracy is required when positioning the load?

While determining the answers to these and other questions is beyond the scope of this document, they are details that you must know in order to select a motor that is appropriate for your application. These details will affect everything from the power supply voltage to the type and wiring configuration of your stepper motor. The current and microstepping settings of your MForce MicroDrive will also be affected.

Types and Construction of Stepping Motors

The stepping motor, while classed as a DC motor, is actually an AC motor that is operated by trains of pulses. Although it is called a “stepping motor”, it is in reality a polyphase synchronous motor. This means it has multiple phases wound in the stator and the rotor is dragged along in synchronism with the rotating magnetic field. The MForce MicroDrive is designed to work with the following types of stepping motors:

- 1) Permanent Magnet (PM)
- 2) Hybrid Stepping Motors

Hybrid stepping motors combine the features of the PM stepping motors with the features of another type of stepping motor called a variable reluctance motor (VR). VR motors are low torque and load capacity motors which are typically used in instrumentation. The MForce MicroDrive cannot be used with VR motors as they have no permanent magnet.

On hybrid motors, the phases are wound on toothed segments of the stator assembly. The rotor consists of a permanent magnet with a toothed outer surface which allows precision motion accurate to within ± 3 percent. Hybrid stepping motors are available with step angles varying from 0.45° to 15° with 1.8° being the most commonly used. Torque capacity in hybrid steppers ranges from 5 - 8000 ounce-inches. Because of their smaller step angles, hybrid motors have a higher degree of suitability in applications where precise load positioning and smooth motion is required.

Sizing a Motor for Your System

The MForce MicroDrive is a bipolar driver which works equally well with both bipolar and unipolar motors (i.e. 8 and 4 lead motors, and 6 lead center tapped motors).

To maintain a given set motor current, the MForce MicroDrive chops the voltage using a variable chopping frequency and a varying duty cycle. Duty cycles that exceed 50% can cause unstable chopping. This characteristic is directly related to the motor's winding inductance. In order to avoid this situation, it is necessary to choose a motor with a low winding inductance. The lower the winding inductance, the higher the step rate possible.

Winding Inductance

Since the MForce MicroDrive is a constant current source, it is not necessary to use a motor that is rated at the same voltage as the supply voltage. What is important is that the MForce MicroDrive is set to the motor's rated current.

The higher the voltage used the faster the current can flow through the motor windings. This in turn means a higher step rate, or motor speed. Care should be taken not to exceed the maximum voltage of the driver. Therefore, in choosing a motor for a system design, the best performance for a specified torque is a motor with the lowest possible winding inductance used in conjunction with highest possible driver voltage.

The winding inductance will determine the motor type and wiring configuration best suited for your system. While the equation used to size a motor for your system is quite simple, several factors fall into play at this point.

The winding inductance of a motor is rated in milliHenrys (mH) per Phase. The amount of inductance will depend on the wiring configuration of the motor.

The per phase winding inductance specified may be different than the per phase inductance seen by your MForce MicroDrive driver depending on the wiring configuration used. Your calculations must allow for the actual inductance that the driver will see based upon the wiring configuration.

N

NOTE: In calculating the maximum phase

inductance, the minimum supply output voltage should be used when using an unregulated supply.

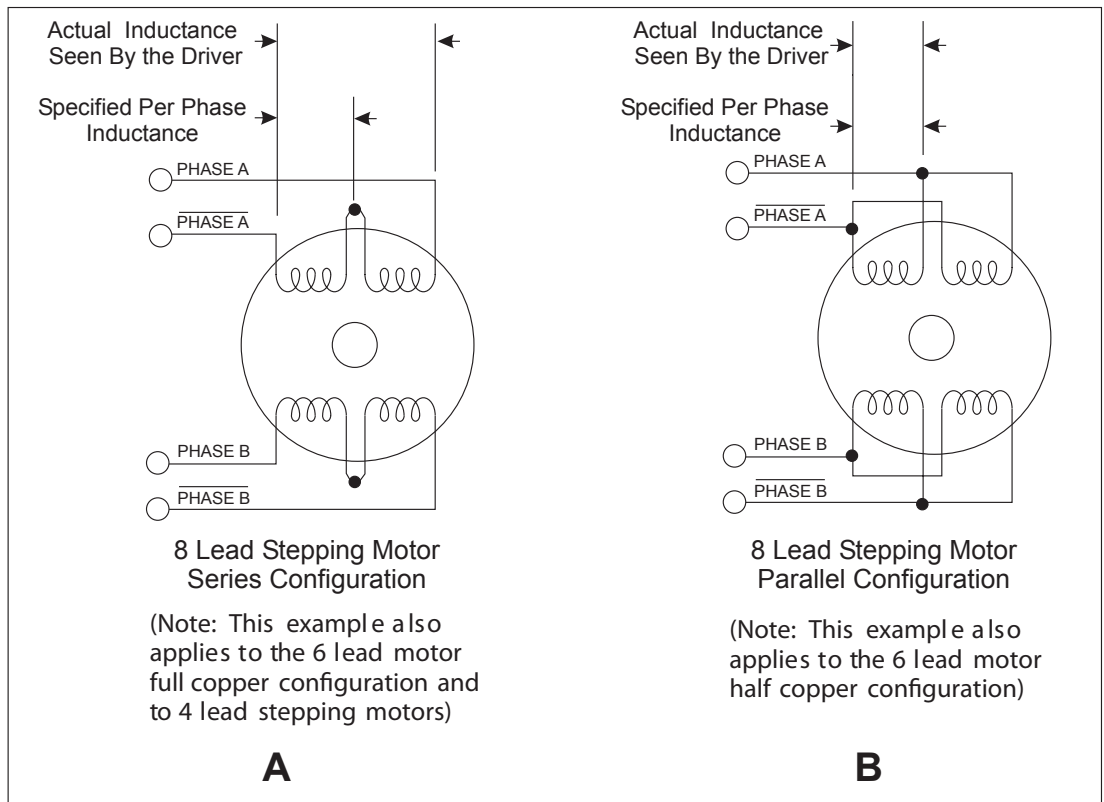

Figure 2.3.1 A & B: Per Phase Winding Inductance

Figure 2.3.1A shows a stepper motor in a series configuration. In this configuration, the per phase inductance will be 4 times that specified. For example: a stepping motor has a specified per phase inductance of 1.47mH. In this configuration the driver will see 5.88 mH per phase.

Figure 2.3.1B shows an 8 lead motor wired in parallel. Using this configuration the per phase inductance seen by the driver will be as specified.

$$\text{Maximum Motor Inductance (mH per Phase)} = .2 \times \text{Minimum Supply Voltage}$$

Using the following equation we will show an example of sizing a motor for an MForce MicroDrive used with an unregulated power supply with a minimum voltage (+V) of 18 VDC:

$$.2 \times 18 = 3.6 \text{ mH}$$

The recommended per phase winding inductance we can use is 3.6 mH.

Recommended IMS Motors

IMS also carries a series of 14, 17 and 23 frame enhanced stepping motors that are recommended for use with the MForce MicroDrive. These motors use a unique relationship between the rotor and stator to generate more torque per frame size while ensuring more precise positioning and increased accuracy.

The special design allows the motors to provide higher torque than standard stepping motors while maintaining a steadier torque and reducing torque drop-off.

These CE rated motors are ideal for applications where higher torque is required.

For more detailed information on these motors, please see the IMS Full Line catalog or the IMS web site at <http://www.imshome.com>.

14 Frame Enhanced (0.75A)

Single Shaft	Double Shaft
M-1410-0.75S	M-1410-0.75D

17 Frame Enhanced (1.5A)

Single Shaft	Double Shaft
M-1713-1.5S	M-1713-1.5D
M-1715-1.5S	M-1715-1.5D
M-1719-1.5S	M-1719-1.5D

23 Frame Enhanced (2.4A) — Not Available with Double Shaft

Single Shaft	Double Shaft
M-2218-2.4S	N/A
M-2222-2.4S	N/A
M-2231-2.4S	N/A

IMS Inside Out Stepper Motors

The new inside out stepper (IOS) motor was designed by IMS to bring versatility to stepper motors using a unique multi-functional, hollow core design.

This versatile new motor can be converted to a ball screw linear actuator by mounting a miniature ball screw to the front shaft face. Ball screw linear actuators offer long life, high efficiency, and can be field retrofitted. There is no need to throw the motor away due to wear of the nut or screw.

The IOS motors offer the following features:

- The shaft face diameter offers a wide choice of threaded hole patterns for coupling.
- The IOS motor can be direct coupled in applications within the torque range of the motor, eliminating couplings and increasing system efficiency.
- The IOS motor can replace gearboxes in applications where gearboxes are used for inertia damping between the motor and the load. The induced backlash from the gearbox is eliminated providing improved bidirectional position accuracy.
- Electrical or pneumatic lines can be directed through the center of the motor enabling the motors to be stacked end-to-end or applied in robotic end effector applications. The through hole is stationary, preventing cables from being chaffed by a moving hollow shaft.
- Light beams can be directed through the motor for refraction by a mirror or filter wheel mounted on the shaft mounting face.
- The IOS motor is adaptable to valves enabling the valve stem to protrude above the motor frame. The stem can be retrofitted with a dial indicator showing valve position.
- The motor is compatible with IMS bipolar drivers, keeping the system cost low.
- The IOS motor can operate up to 3000 rpm's.

The IOS motor is available in the following frames:

Frame Size	IMS PN
17 Frame.....	M3-1713-IOS
23 Frame.....	M3-2220-IOS



WARNING!
Ensure proper connection of the motor phases prior to power application!

Motor Wiring

As with the power supply wiring, motor wiring should be run separately from logic wiring to minimize noise coupled onto the logic signals. Motor cabling exceeding 1' in length should be shielded twisted pairs to reduce the transmission of EMI (Electromagnetic Interference) which can lead to rough motor operation and poor system performance. Below are listed the recommended motor cables:

Dual Twisted Pair Shielded (Separate Shields)

- ≤ 5 feet Belden Part# 9402 or equivalent 20 Gauge
- ≥ 5 feet Belden Part# 9368 or equivalent 18 Gauge

When using a bipolar motor, the motor must be within 100 feet of the drive.

Connecting the Motor

The motor leads are connected to the following connector pins:

<u>Phase</u>	<u>Connector: Pin</u>
Phase A	P4: 1
Phase A	P4: 2
Phase B	P4: 3
Phase B	P4: 4

8 Lead Motors

8 lead motors offer a high degree of flexibility to the system designer in that they may be connected in series or parallel, thus satisfying a wide range of applications.

Series Connection

A series motor configuration would typically be used in applications where a higher torque at lower speeds is required. Because this configuration has the most inductance, the performance will start to degrade at higher speeds. Use the per phase (or unipolar) current rating as the peak output current, or multiply the bipolar current rating by 1.4 to determine the peak output current.

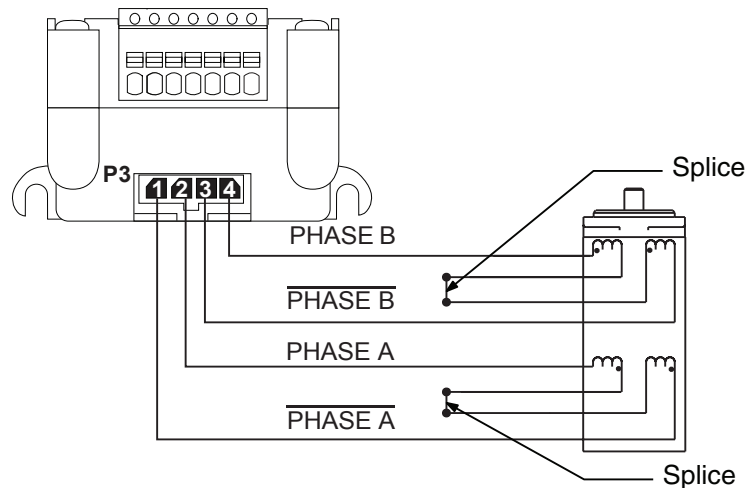

Figure 2.3.2: 8 Lead Motor Series Connections

Parallel Connection

An 8 lead motor in a parallel configuration offers a more stable, but lower torque at lower speeds. But because of the lower inductance, there will be higher torque at higher speeds. Multiply the per phase (or unipolar) current rating by 1.96, or the bipolar current rating by 1.4, to determine the peak output current.

WARNING!
 Ensure proper connection of the motor phases prior to power application!

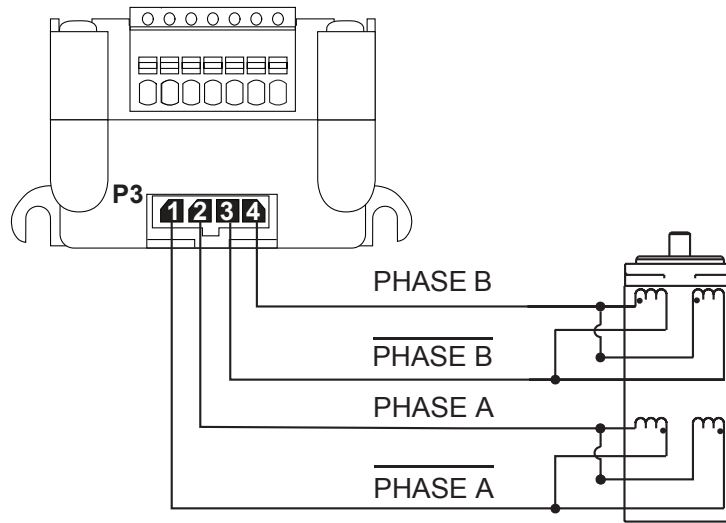

Figure 2.3.3: 8 Lead Motor Parallel Connections

6 Lead Motors

Like 8 lead stepping motors, 6 lead motors have two configurations available for high speed or high torque operation. The higher speed configuration, or half coil, is so described because it uses one half of the motor's inductor windings. The higher torque configuration, or full coil, uses the full windings of the phases.

Half Coil Configuration

As previously stated, the half coil configuration uses 50% of the motor phase windings. This gives lower inductance, hence, lower torque output. Like the parallel connection of 8 lead motor, the torque output will be more stable at higher speeds. This configuration is also referred to as half copper. In setting the driver output current multiply the specified per phase (or unipolar) current rating by 1.4 to determine the peak output current.

Full Coil Configuration

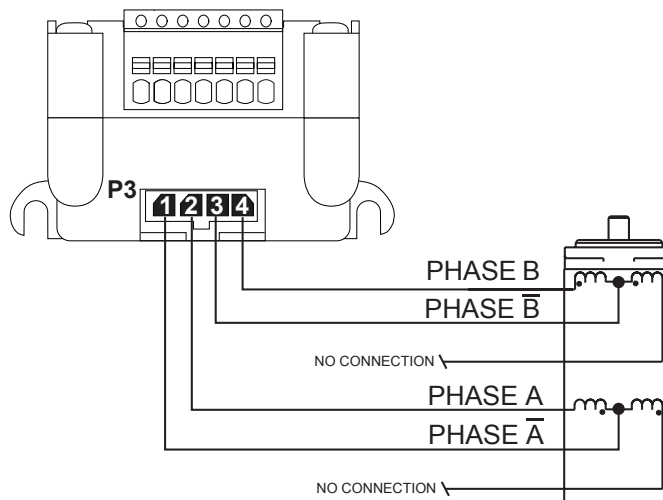

Figure 2.3.4: 6 Lead Half Coil (Higher Speed) Motor Connections

The full coil configuration on a six lead motor should be used in applications where higher torque at lower speeds is desired. This configuration is also referred to as full copper. Use the per phase (or unipolar) current rating as the peak output current.



WARNING!
Ensure proper connection of the motor phases prior to power application!

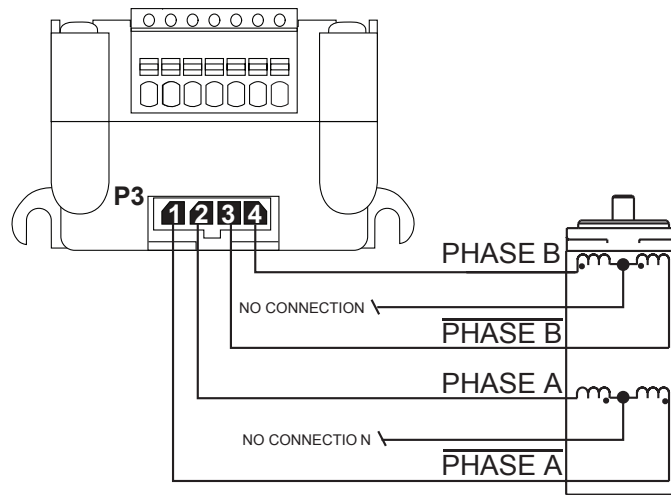

Figure 2.3.5: 6 Lead Full Coil (Higher Torque) Motor Connections

4 Lead Motors

4 lead motors are the least flexible but easiest to wire. Speed and torque will depend on winding inductance. In setting the driver output current, multiply the specified phase current by 1.4 to determine the peak output current.

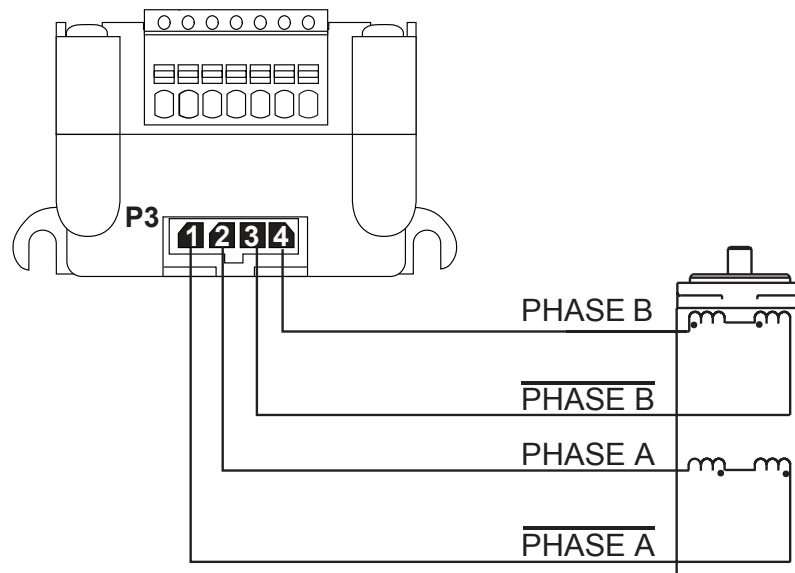

Figure 2.3.6: 4 Lead Motor Connections

Recommended Motor Cabling

As with the power supply wiring, motor wiring should be run separately from logic wiring to minimize noise coupled onto the logic signals. Motor cabling exceeding 1' in length should be shielded twisted pairs to reduce the transmission of EMI (Electromagnetic Interference) which can lead to rough motor operation and poor system performance.

Cable length, wire gauge and power conditioning devices play a major role in the performance of your MForce PowerDrive and Stepper Motor.

NOTE: The length of the DC power supply cable between the MForce MicroDrive and the Motor should not exceed 50 feet.

Example A demonstrates the recommended cable configuration for the MForce MicroDrive to Motor cabling under 50 Feet long. If cabling of 50 feet or longer is required, the additional length can be gained with the cable configuration in Example B.

Correct AWG wire size is determined by the current requirement plus cable length. Please see Table 2.3.1 on the following page.

Example A: Motor Cabling Less Than 50 Feet

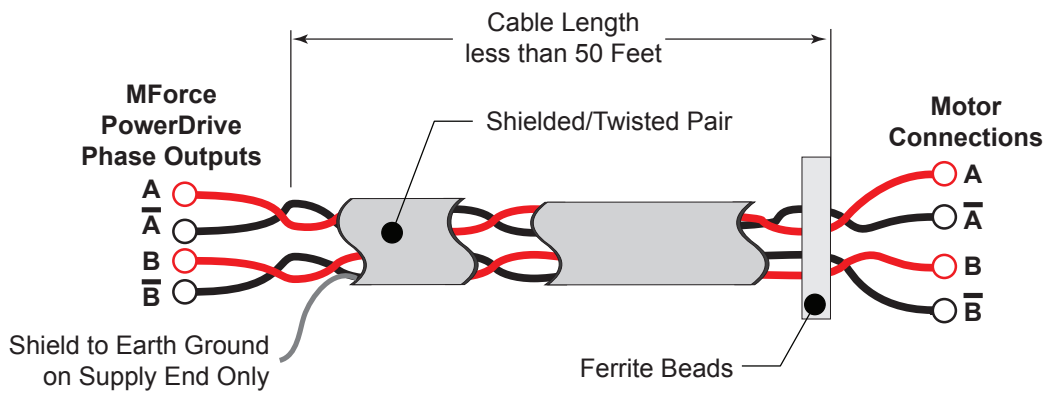
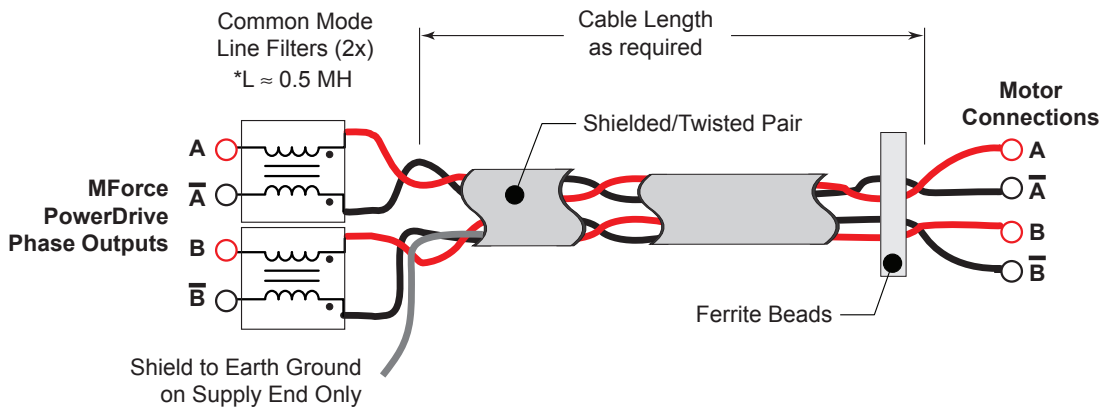

Figure 2.3.7: Motor Cabling Less than 50 Feet

Example B: Motor Cabling Greater Than 50 Feet



* 0.5 MH is a typical starting point for the Common Mode Line Filters. By increasing or decreasing the value of L you can set the drain current to a minimum to meet your application's requirements.

Figure 2.3.8: Motor Cabling Greater than 50 Feet

Recommended Motor Cable AWG Sizes

MForce MicroDrive Recommended Motor Cable AWG					
1 Amperes (Peak)					
Length (Feet)	10	25	50*	75*	100*
Minimum AWG	20	20	18	18	16
2 Amperes (Peak)					
Length (Feet)	10	25	50*	75*	100*
Minimum AWG	20	18	16	14	14
3 Amperes (Peak)					
Length (Feet)	10	25	50*	75*	100*
Minimum AWG	18	16	14	12	12
*Use the alternative methods illustrated in example B when cable length is \geq 50 feet. Also, use the same current rating when the alternate AC power is used.					

Table 2.3.1: Recommended Wire Gauges

Interfacing Communications

Available Communications Cables/Converters

To simplify the wiring and connection process IMS offers a USB to RS-422 communications cable for the MForce MicroDrive. This convenient 12.0' (3.6m) accessory cable connects a PC's USB Port to the MForce MicroDrive P2 Connector. An in-line RS-422 converter enables parameter setting to a single MForce MicroDrive. Cable purchase recommended with first orders.

- USB to 10-Pin IDCPart No. MD-CC400-000
- 10-Pin IDC to Wire Crimp AdapterPart No. MD-ADP-H

For more information on these cables please reference Appendix D: Optional Cables and Cordsets.

Interfacing Single Mode Communications

The MForce MicroDrive communicates to the host using the RS-422/485 protocol. Communications may be configured as either half duplex (RS-485) or full duplex (RS-422) using the EM (Echo Mode) Instruction. RS-422/485 may be used in two ways: either to communicate to a single MForce MicroDrive, or to address up to 62 individually named MForce MicroDrive nodes in a multidrop system.

Single Mode Communications Full Duplex (RS-422)

To interface the MForce MicroDrive using RS-422 protocol you will need one of the following:

- A PC equipped with RS-422 Interface.
- A PC RS-232 to RS-422/485 Converter.
- The USB to RS-422 accessory cable.

Use the following diagram to connect RS-422 communications to the MForce MicroDrive.

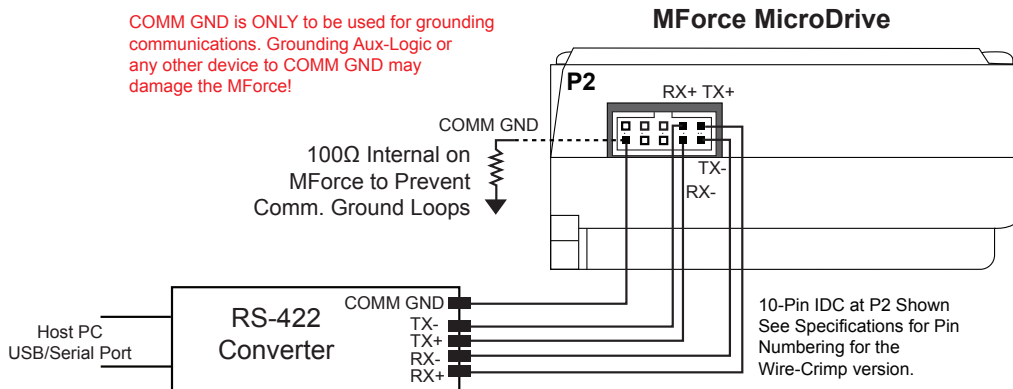

Figure 2.4.1: Full Duplex Communications (RS-422)



Note: See the Specifications Section of this document

specific to the MForce MicroDrive model you purchased for detailed connector and pin information.



WARNING!
Do not connect or disconnect

the Communications Converter Cable while power is applied!



WARNING!
If using AUX-Logic, the Power return

MUST be connected to the Motor Power Ground. DO NOT connect the return to Communications Ground!

Single Mode Communications Half Duplex (RS-485)

The MForce MicroDrive can be operated in a 2 wire RS-485 communication bus. Before connecting the 2 wire RS-485, download your program and setup instructions using the standard 4 wire RS-422 Communications Cable. If a program is not being used, download and save any setup parameters. To ensure the MForce MicroDrive responds only to commands specifically meant for it, set the unit in Party Mode (Please see Party Mode below). The Echo Mode command (EM) must be set to the value of 1 (EM=1). This will set the MForce MicroDrive communication into “half duplex” mode. Connect the driver in the 2 wire RS-485 configuration. The following diagram illustrates how to connect the MForce MicroDrive 4 wire RS-485 to operate as a 2 wire system.

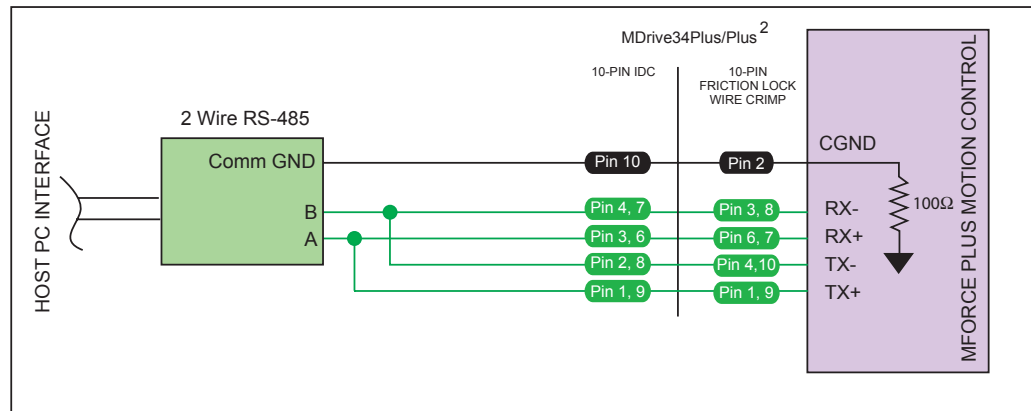

Figure 2.4.2: Half Duplex 2 Wire Communications (RS-485)

Interfacing Party Mode Communications

In systems with multiple controllers it is necessary to communicate with the control modules using party mode (PY=1). The MForce MicroDrive nodes in the system are configured in software for this mode of operation by setting the Party Flag (PY) to True (1). It is necessary for all of the nodes in a system to have this configuration selected. When operating in party mode, each MForce in the system will need a unique address, or name, to identify it in the system. This is accomplished by using the software command DN, or Device Name. For example, to set the name of an MForce to “A” you would use the following command: DN=65 or DN=“A” (65 is the ASCII decimal equivalent of uppercase A). The factory default name is “!”. The asterisk character “*” is used to issue global commands to every device in the system. NOTE: When using the asterisk “*” in Party Mode, typed entries and commands will not be echoed. See Appendix A of the Software Reference for ASCII table.

In setting up your system for party operation, the most practical approach is to observe the following steps:

1. Connect the first MForce MicroDrive to the Host PC configured for Single Mode Operation.
2. Establish communications and download program if required.
3. Using the command DN, name the MForce MicroDrive. This can be any upper or lower case ASCII character or number 0-9. (DN=“A”{enter}) (Note: The quotation marks before and after the device name are required.)
4. Set the party flag PY=1{enter}.
5. Press CTRL+J to activate the Party Mode.
6. Type the letters AS and press CTRL+J (Save device name and Party Mode).
7. Remove power.
8. Repeat steps 1 through 7 for each additional MForce in the system.
9. After all MForce MicroDrives are assigned a Device Name, the Multiple MForce Interface can be configured as shown in the following figure.

Data Cable Termination Resistors

Data Cable lengths greater than 15 feet (4.5 meters) are susceptible to signal reflection and/or noise. IMS recommends 120 Ω termination resistors in series with 0.1μf capacitors at both ends of the Data Cables. An example of resistor placement is shown in Figure 2.4.3. For systems with Data Cables 15 feet (4.5 meters) or less, the termination resistors are generally not required.

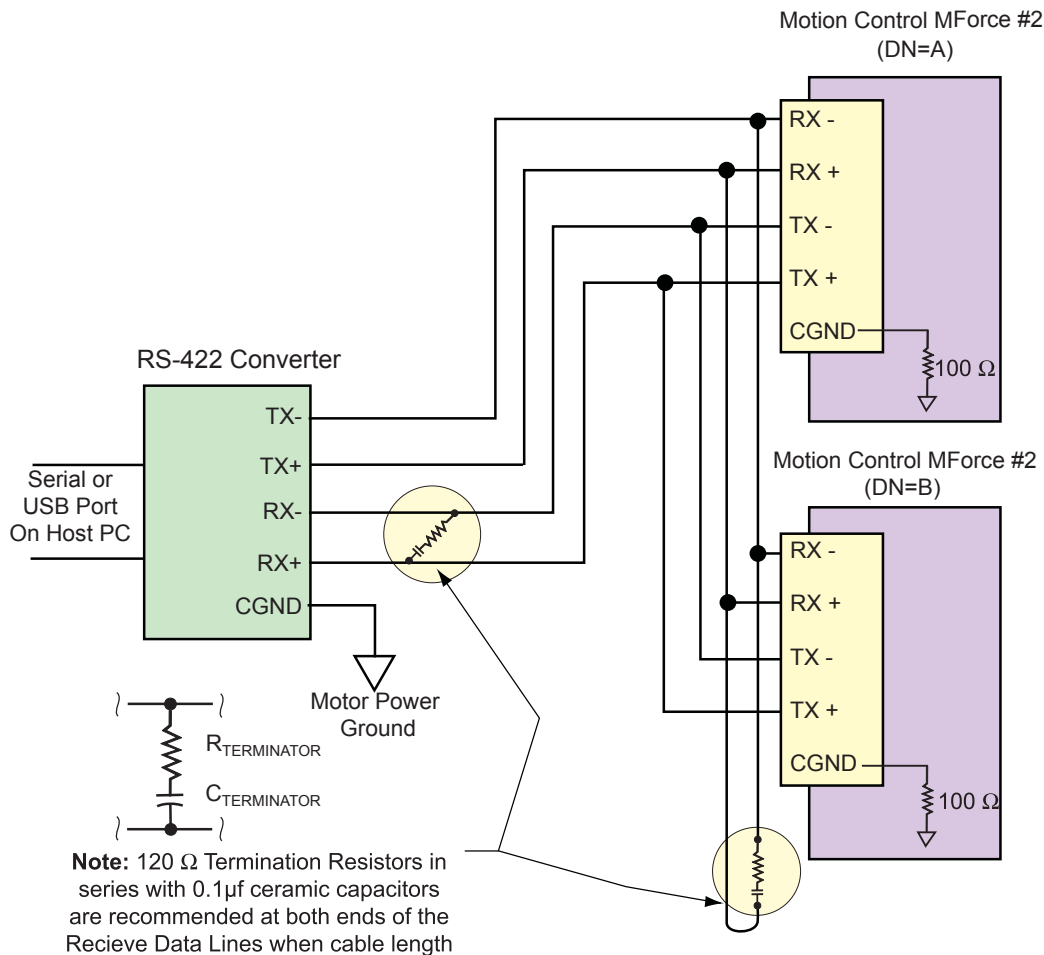

Figure 2.4.3: RS-485 Interface, Multiple MForce MicroDrive System

Avoiding Communications Ground Loops in Party Mode

Ground and ground loops are an important consideration in designing a multi-drop communications environment. Large currents may exist through the system grounds, leading to voltage differences of the ground reference in different parts of the system. This can lead to communications errors and possible damage to the RS-422/483 transceivers in the device. There are two different techniques that can be applied to eliminate the potential for ground loops.

1. Non-isolated Communications Converter: Connect COM GND to the return (GND) of the motor power supply. Do not use the COM GND on the unit.
2. Isolated Communications Converter: Connect COM GND to the COM GND of the FIRST UNIT ONLY. Do not connect the COM GND of subsequent units in the system.

These techniques are shown in the next two illustrations.

With all system wiring, remember to follow the Wiring and Noise Shielding Best Practices located on the web at http://www.imshome.com/support/wiring_noise_shielding_bp.html.

Multi-drop Wiring: Non-Isolated Communications

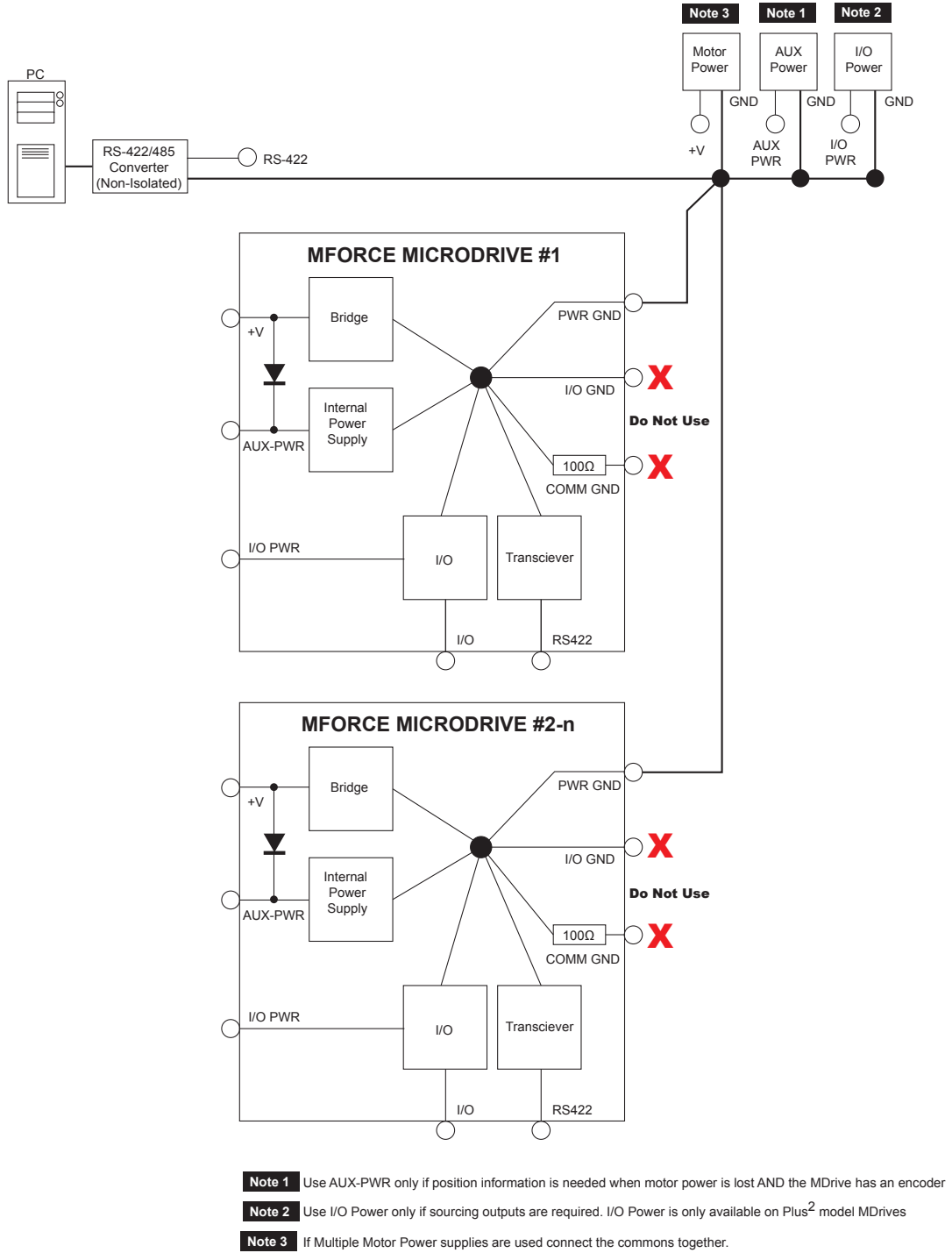

Figure 2.4.4: Recommended Multi-drop Connection using a Non-Isolated Communications Converter

Multi-drop Wiring: Isolated Communications

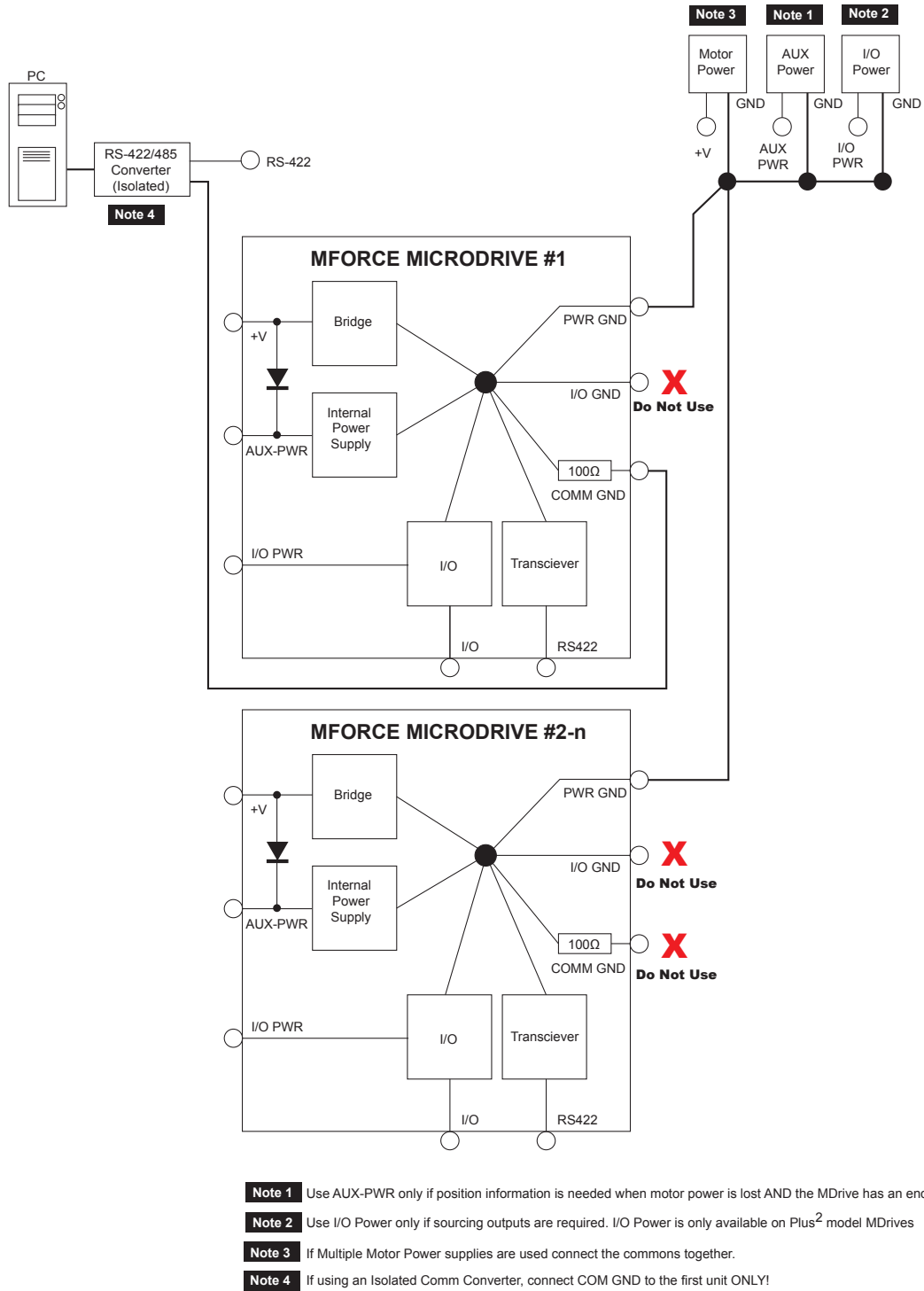

Figure 2.4.5: Recommended Multi-drop Connection using an Isolated Communications Converter

MForce MicroDrive Communication Format

The following communication formats are used by the MForce MicroDrive.

```

{}          The contents between the {} symbols are transmitted.
{0D}       Hex equivalent for a CR (Carriage Return).
{0A}       Hex equivalent for a LF (Line Feed).
{DN}       Represents the Device Name being sent.
{CS}       Check Sum; {ACK} 06 Hex; {NAK} 15 Hex

EM = Echo Mode;  PY = Party Mode;  CK= Check sum
    
```

The word {command} represents the immediate command sent to the MForce MicroDrive.

Command Execution Time (CET) is the time the MForce MicroDrive takes to execute a command. This varies from command to command and usually is in the 1-5 millisecond range.

MForce MicroDrive Response to Echo Mode

Dependent on how the Echo Mode (EM) is set in conjunction with Party Mode (PY) and Check Sum (CK), the MForce MicroDrive will respond differently. The following tables illustrate the various responses based on how the EM, PY and CK parameters are set.

Parameter Setting	Transmission to MForce MicroDrive	MForce MicroDrive Initial Response	MForce MicroDrive Final Response	Notes
EM=0 & PY=0 CK=0	(command) (D)	(command) Echoed back one character at a time as the character is entered.	CET (0D) (0A)>	The last character sent is the prompt >
EM=1 & PY=0 CK=0	(command) (0D)	-	CET (0D) (0A)	The last character sent is LF
EM=2 & PY=0 CK=0	(command) (0D)	-	-	No response except to PR and L commands
EM=3 & PY=0 CK=0	(command) (0D)	-	CET command (0D) (0A)	Queued response. The last character sent is the LF

Table 2.4.1: MForce MicroDrive Response to Echo Mode - Party and Check Sum are Zero (0)

Parameter Setting	Transmission to MForce MicroDrive	MForce MicroDrive Initial Response	MForce MicroDrive Final Response	Notes
EM=0 & PY=1 CK=0	(DN) (command) (0A)	(command) Echoed back one character at a time as the character is entered.	CET (0D) (0A)>	The last character sent is the prompt >
EM=1 & PY=1 CK=0	(DN) (command) (0A)	-	CET (0D) (0A)	The last character sent is LF
EM=2 & PY=1 CK=0	(DN) (command) (0A)	-	-	No response except to PR and L commands
EM=3 & PY=1 CK=0	(DN) (command) (0A)	-	CET command (0D) (0A)	Queued response. The last character sent is the LF

Table 2.4.2: MForce MicroDrive Response to Echo Mode - Party is One (1) and Check Sum is Zero (0)

Parameter Setting	Transmission to MForce MicroDrive	MForce MicroDrive Initial Response	MForce MicroDrive Final Response	Notes
EM=0 & PY=0 CK=1	(DN) (command) (0A)	(command) Echoed back one character at a time as the character is entered.	CET (0D) (0A)>	The last character sent is the prompt >
EM=1 & PY=0 CK=1	(DN) (command) (0A)	-	CET (0D) (0A)	The last character sent is LF
EM=2 & PY=0 CK=1	(DN) (command) (0A)	-	-	No response except to PR and L commands
EM=3 & PY=0 CK=1	(DN) (command) (0A)	-	CET command (0D) (0A)	Queued response. The last character sent is the LF

Table 2.4.3: MForce MicroDrive Response to Echo Mode - Party is Zero (0) and Check Sum is One (1)

Parameter Setting	Transmission to MForce MicroDrive	MForce MicroDrive Initial Response	MForce MicroDrive Final Response	Notes
EM=0 & PY=1 CK=1	(DN) (command) (CS) (0A)	(command) Echoed back one character at a time as the character is entered.	CET (ACK) or (NAK)>	The last character sent is the prompt >
EM=1 & PY=1 CK=1	(DN) (command) (CS) (0A)	-	CET (ACK) or (NAK)>	The last character sent is ACK or NAK
EM=2 & PY=1 CK=1	(DN) (command) (CS) (0A)	-	-	No response except to PR and L commands
EM=3 & PY=1 CK=1	(DN) (command) (CS) (0A)	-	CET command (CS) (ACK) (NAK)	Queued response. The last character sent is ACK or NAK

Table 2.4.4: MForce MicroDrive Response to Echo Mode - Party and Check Sum are One (1)

Using Check Sum

For communication using Check Sum, the following 2 commands demonstrate sending and receiving.

Sending Command

1. Check Sum set to ZERO before first character is sent.
2. All characters (ASCII values) are added to Check Sum, including the Device Name DN (if PY=1), to the end of the command, but not including terminator.
3. Check Sum is 2's complement, then "OR" ed with Hex 80 (prevents Check Sum from being seen as Command Terminator).
4. Terminator Sent.

Example command:

MR (space) 1	Note: Any combination of upper/lower case may be used. In this example, if a lower case <mr> were to be used, the decimal values will change to 109 and 114. Subsequently the Result Check Sum value will change. (Possible entries: MR, mr, Mr, mR.) (M = 77, R = 82, m = 109, r = 114) (See ASCII table appendix in MForce MicroDrive Software Manual.)
77 82 32 49	Decimal value of M, R, <space> and 1
4D 52 20 31	Hex
77+82+32+49 = 240	Add decimal values together
1111 0000 = 240	Change 240 decimal to binary
0000 1111	1's complement (invert binary)
0001 0000	Add 1 [2's complement]
1000 0000	OR result with 128 (Hex 80)
1001 0000 144	Result Check Sum value

Once the result is reached, add the check Sum value (144 in this example) to your string by typing: MR 1(Alt Key + 0144) (Use the symbol of 0144 in your string by holding down the alt key and typing 0144). You must type the numbers from the Numlock key pad to the right of the keyboard. The numbers at the top of the keyboard will not work.

Receiving Command

1. Check Sum set to ZERO.
2. All characters are added to Check Sum.
3. When receiving a Command Terminator, the lower 7 bits of the Check Sum should be equal to ZERO.
 - a) If not ZERO, the command is ignored and NAK echoed.
 - b) If ZERO, ACK is sent instead of CR/LF pair.
4. Responses to PR commands will be Check Summed as above, but the receiving device should NOT respond with ACK or NAK.

MForce MicroDrive Party Mode Sample Codes

1. Download this segment of code into the first MForce MicroDrive. After downloading the program to the unit, follow the Set Up instructions described earlier. Be sure to set your first unit with the unique Device Name of A (DN="A"). The device name is case sensitive.

```
RC=25           `Run current
HC=5            `Hold current
MS=256         `Microstep selection
A=250000       `Acceleration
D=250000       `Deceleration
PG 1           `Enter program mode
S1=0,0        `Setup I/O 1 as an input low true
LB SU         `Start program upon power up
LB AA         `Label program AA
MR 104400     `Move relative 104400 counts
H             `Hold program execution to complete the move
LB DD         `Label program DD
BR DD,I1=0    `Branch to DD if I1=0
4PR "Bex 1"   `Print device name B to execute program
              `at address 1
H 2000        `Hold program execution 2000 milliseconds
PR "Cex 1"   `Print device name C to execute program at
              `address 1
H 2000        `Hold program execution 2000 milliseconds
BR AA        `Branch to label AA
E            `Exit program, return to immediate mode
PG           `Exit program, return to immediate mode
```

2. Download this segment of code into your second MForce MicroDrive. After downloading the program to the unit, follow the previous party mode instructions. Be sure to set your second unit with the unique address of B (device name is case sensitive).

```

RC=25          `Run current
HC=5           `Hold current
MS=256        `Microstep selection
A=250000      `Acceleration
D=250000      `Deceleration
PG 1          `Enter program mode
LB BB         `Label program BB
MR 208000     `Move relative 208000 counts
H             `Hold program execution to complete the move
E
PG            `Exit program, return to immediate mode

```

- Download this segment of code into your third MForce MicroDrive. After downloading the program to the unit, follow the previous party mode instructions. Be sure to set your third unit with the unique address of C (device name is case sensitive).

```

RC=25          `Run current
HC=5           `Hold current
MS=256        `Microstep selection
A=250000      `Acceleration
D=250000      `Deceleration
PG 1          `Enter program mode
LB CC         `Label program CC
MR 300000     `Move relative 300000 counts
H             `Hold program execution to complete the move
E
PG            `Exit program, return to immediate mode

```



MForce MicroDrive Immediate Party Mode Sample Codes

Once Party Mode has been defined and set up as previously described under the heading “Multiple MForce MicroDrive System (Party Mode)”, you may enter commands in the Immediate Mode in the IMS Terminal Window. Some examples follow.

Move MForce A, B or C 10000 Steps

Assuming there are three MForce MicroDrives set up in Party Mode as shown in the Sample Codes above.

- To move MForce Unit “A”, Press Ctrl+J and then type: AMR^10000 and press Ctrl+J. MForce Unit “A” will move 10000 steps.
- To print the position type: APR P and press Ctrl+J. The position of MForce Unit “A” will be printed.
- To move MForce Unit “B” type: BMR 10000 and press Ctrl+J. MForce Unit “B” will move 10000 steps.
- To move all three MForce MicroDrives at the same time type: *MR 10000 and press Ctrl+J. All MForce MicroDrives will move 10000 steps.
- To change a Variable in the “C” unit type: C<variable name><number> and press Ctrl+J. The variable will be changed. To verify the change type: CPR <variable name> and press Ctrl+J. The new value will be displayed. All Commands and Variables may be programmed in this manner.
- To take an MForce out of Party Mode type: <device name>PY=0 and press Ctrl+J. That unit will be taken out of Party Mode. To take all units out of Party Mode type: *PY=0 and press Ctrl+J. All units will be taken out of Party Mode.

N NOTE: When instructed to type Ctrl+J, that is the key  + the  key. It will not display in the Terminal Window so be certain you press the correct keys. CtrlJ activates the Party Mode.

N NOTE: Once you have activated Party Mode with the first Ctrl+J you do not have to type it before each successive command. However, every command must be followed with a Ctrl+J.

N NOTE: The asterisk (*) is a global command which addresses all units. Since three units can not answer together, the asterisk (*) as well as other global commands will not be displayed in the Terminal Window.

This Page Intentionally Left Blank

SECTION 2.5

Interfacing and Using the MForce MicroDrive I/O

The MForce MicroDrive Digital I/O

The MForce MicroDrive product line is available with two digital I/O configurations, Standard and Enhanced.

The digital I/O may be defined as either active HIGH or active LOW. When the I/O is configured as active HIGH, the level is +5 to +24 VDC and the state will be read/set as a “1”. If the level is 0 VDC, then the state will be read/set as “0”. Inversely, if configured as active LOW, then the state of the I/O will be read/set as a “1” when the level is LOW, and “0” when the level is HIGH. The active HIGH/LOW state is configured by the third parameter of the I/O Setup (S1-4, S9-12) variable. The goal of this I/O configuration scheme is to maximize compatibility between the MForce MicroDrive and standard sensors and switches.

Standard	All MForce MicroDrive
Available Points	IO1, IO2, IO3, IO4 (Sinking or Sourcing Inputs, Sinking Outputs ONLY)
Enhanced (16-Pin)	Plus² Only
Available Points	IO1, IO2, IO3, IO4 (Sinking Sourcing, Outputs/Inputs)
Additional Points.....	IO9, IO10, IO11, IO12 (Sinking Sourcing, Outputs/Inputs)
Dedicated I/O	Step/Clock Input, Step/Direction I/O, Capture Input/Trip Output
Remote Encoder Configuration (16-Pin)	Plus² Only
Available Points	IO1, IO2, IO3, IO4 (Sinking Sourcing, Outputs/Inputs)
Dedicated I/O	Capture Input/Trip Output
Remote Encoder I/O	Channel A±, Channel B±, Index±

N NOTE: On the Standard MForce MicroDrive, when configured as outputs, the I/O set is sinking ONLY! The Plus² Models add the functionality of I/O Power, which enables the user to use all the outputs, both Standard and Enhanced, as Sinking or Sourcing.

N NOTE: If the unit purchased has the remote encoder option, the additional points become dedicated to encoder functions!

Standard I/O Set

The MForce MicroDrive comes standard with a set of four I/O — (4) sinking or sourcing 0 to +24 VDC inputs or (4) sinking 0 to +24 VDC outputs, which may be programmed individually as either general purpose or dedicated inputs or outputs, or collectively as a group.

Enhanced I/O Set - MForce MicroDrive Plus² Version

The MForce MicroDrive Plus² Version is equipped with a set of eight I/O — (8) sinking or sourcing 0 to +24 VDC inputs or (8) sinking or sourcing +12 to +24 VDC outputs, which may be programmed individually as either general purpose or dedicated inputs or outputs, or collectively as a group. The eight I/O consist of two separate banks of four points: Bank 1: IO1 - IO4, Bank 2: IO9 - IO12.

Uses of the Digital I/O

The I/O may be utilized to receive input from external devices such as sensors, switches or PLC outputs. When configured as outputs, devices such as relays, solenoids, LEDs and PLC inputs may be controlled from the MForce MicroDrive.

Each I/O point may be individually programmed to any one of 9 dedicated input functions, 4 dedicated output functions, or as general purpose inputs or outputs. The I/O may be addressed individually, or as a group. The active state of the line or group may also be set. All of these possible functions are accomplished with the I/O Setup Variable (S1-4, S9-12)

When the level is HIGH. The active HIGH/LOW state is configured by the second parameter of the I/O Setup (S1-4,

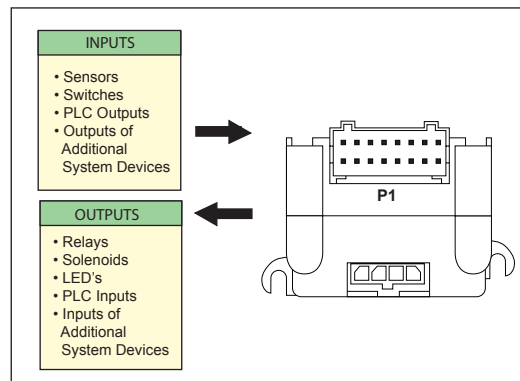

Figure 2.5.1: Uses for the Digital I/O

S9-12) variable. The goal of this I/O configuration scheme is to maximize compatibility between the MForce MicroDrive and standard sensors and switches.

MForce MicroDrive Digital Input Functions

The MForce MicroDrive inputs may be interfaced to a variety of sinking or sourcing devices. An input may be programmed to be a general purpose user input, or to one of nine dedicated input functions. These may then be programmed to have an active state of either HIGH or LOW.

The inputs are configured using the “S” Variable (See MCode Software Reference Manual for precise details on this command). The command is entered into the IMS terminal or program file as S<IO point>=<IO Type>,<Active State><Sink/Source>.

Example:

```
S9=3,1,0    `set IO point 9 to be a Limit- input, Active HIGH, Sourcing
S3=0,0,1    `set IO Point 3 to be a General Purpose input, Active LOW,
             `Sinking
```

Input Functions (I/O Points 1-4, 9-12)

The following table lists the programmable input functions of the MForce.

Function	Description	Parameter (S1-S4, S9-S12)	Active	Sink/Source
General Purpose	General Purpose Input function used to control program branches, subroutine calls or BCD functions when input bank is used as a group	0	0/1	0/1
Home	Homing input. Will function as specified by the Home (HM) command.	1	0/1	0/1
Limit +	Positive Limit Input. Will function as specified by the Limit (LM) Command.	2	0/1	0/1
Limit –	Negative Limit Input. Will function as specified by the Limit (LM) Command.	3	0/1	0/1
G0	G0 Input. Will run program located at address 1 on activation.	4	0/1	0/1
Soft Stop	Soft Stop input. Stops motion with deceleration and stops program execution.	5	0/1	0/1
Pause	Pause/Resume program with motion.	6	0/1	0/1
Jog +	Will Jog motor in the positive direction at Max. Velocity (VM). The Jog Enable (JE) Flag must be set for this to function.	7	0/1	0/1
Jog –	Will Jog motor in the negative direction at Max. Velocity (VM). The Jog Enable (JE) Flag must be set for this to function.	8	0/1	0/1
Reset	When set as RESET input, then the action is equivalent to a ^C entered into a terminal.	11	0/1	0/1

Table 2.5.1: Programmable Input Functions

Input Functions (Points 7 & 8 — Clock Inputs and Point 13 — Capture)

Function	Description	Parameter (S7, S8)	Active
Step/Direction	Sets I/O 7 and 8 to receive step and direction inputs from an external source. The motion will occur based on the input frequency seen at I/O 7 in the Direction relative to the logic state of I/O 8. The step rate will be based upon the ratio set by Clock Ratio (CR)	33	0/1
Quadrature	Sets I/O 7 and 8 to receive Channel A and Channel B Quadrature inputs from an external source such as an encoder. The motion will follow the Quadrature Input.	34	0/1
Up/Down	Sets I/O 7 and 8 to receive Clock Up/ Clock Down inputs from an external source. The motion will occur based upon the input clock frequency in the direction relative to the input being clocked. The step rate will be based upon the ratio set by Clock Ratio (CR)	35	0/1
Function	Description	Parameter (S13)	Active
High Speed Capture	The Capture input is a momentary high speed input that operates with the Trip Capture (TC) variable to run a subroutine upon the trip. It feature variable input filtering ranging from 50 nS to 12.9 μ S	60	0/1

Table 2.5.2: Dedicated Input Functions

N NOTE: On the Standard MForce MicroDrive, when configured as outputs, the I/O set is sinking **ONLY!** The Plus² Models add the functionality of I/O Power, which enables the user to use all the outputs, both Standard and Enhanced, as Sinking or Sourcing.

Active States Defined

The Active State determines at what voltage level the input will be active.

Active HIGH The input will be active when +5 to +24 VDC is applied to the input.

Active LOW The input will be active when it is grounded (0 VDC).

Active LOW example:

IO 1 is to be configured as a Jog- input which will activate when a switch is toggled to ground (Sinking Input):

```
S1=8,0,0    `set IO point 1 to Jog-, Active LOW, Sinking
```

Active HIGH example:

IO 4 is to be configured as a Home input which will activate when instructed by a PLC (+24VDC Sourcing Input):

```
S4=1,1,1    `set IO point 1 to Home, Active HIGH, Sourcing
```

MForce MicroDrive Digital Output Functions

The MForce MicroDrive Outputs may be configured as general purpose or set to one of two dedicated functions, Fault or Moving. These outputs will sink up to 600 mA (one channel of two banks) and may be connected to an external VDC source. See Output Functions Table and I/O Ratings Table.

The outputs are set using the “S” command (See MCode Software Reference Manual for precise details on this command). The command is entered into the IMS terminal or program file as S<IO point>=<IO Type>,<Active State><Sink/Source>.

Example:

```
S9=17,1,0    `set IO point 9 to be a Moving Output, Active HIGH, Sinking
S3=18,0,0    `set IO Point 3 to be a Fault Output, Active LOW, Sinking
```

Programmable Output Functions

The MForce MicroDrive Output functions may be programmed to be a general purpose user output or to one of five output functions.

Function	Description	Parameter (S1-S4, S9-S12)	Active	Sink/Source
General Purpose User	A general purpose output can be set in a program or in immediate mode to trigger external events. When used as a group they can be a BCD output.	16	0/1	0/1
Moving	Will be in the Active State when the motor is moving.	17	0/1	0/1
Fault	Will be in the Active State when an error occurs. See Software Manual for error code listing.	18	0/1	0/1
Stall	Will be in the Active State when a stall is detected. Encoder Required, Stall Detect Mode (SM) must be enabled.	19	0/1	0/1
Velocity Changing	Will be in the Active State when the velocity is changing. Example: during acceleration and deceleration.	20	0/1	0/1

Table 2.5.3: Programmable Output Functions

Output Functions (Points 7 & 8 – Clock Outputs and Point 13 – Trip)

Function	Description	Parameter (S7, S8)	Active
Step/Direction	Step clock pulses will be output from Point 7, Direction from Point 8. The step clock output rate will be based upon the Pulse Width set by Clock Width (CW). The logic state of the Direction output will be with respect to the direction of the motor.	49	0/1
Quadrature	Will output Quadrature signals.	50	0/1
Up/Down	Will output Clock Up/Clock Down signals. The step clock output rate will be based upon the Pulse Width set by Clock Width (CW). The Active output will be based on the motor direction.	51	0/1
Function	Description	Parameter (S13)	Active
High Speed Trip	The trip output will activate on Position Trips (TP) only. The output will pulse out at the trip point. The pulse width will be determined by Clock Width (CW)	61	0/1

Table 2.5.4: Dedicated Output Functions

MForce MicroDrive I/O Ratings

MForce MicroDrive I/O Ratings			
Standard Output Voltage (IOPWR) Rating	0 to +24 VDC		
Expanded Plus ² Output Voltage (IOPWR) Rating	+12 to +24 VDC (Sourcing) 0 to +24 VDC (Sinking)		
Load Rating* (equal current per I/O Point) * Heatsink Temp = 85°C	I/O State	I Continuous	I Peak (D=0.84)
	1 on, 3 off	550 mA	600 mA
	2 on, 2 off	390 mA	425 mA
	3 on, 1 off	320 mA	350 mA
	4 on, 0 off	275 mA	300 mA
To compute FET dissipation for unequal loads, calculate the FET power for each I/O not to exceed 425 mW.			
Continuous Current	FET Power = $I_{cont}^2 \times 1.4$		
Peak Current	FET Power = $I_{peak}^2 \times D \times 1.4$		
Duty Cycle	(D = T on / T period) = ≤ 1.0 seconds at 85°C heatsink temperature.		
Protection Ratings			
Independent Over-temperature			
Current Limit	0.6A to 1.2 A		
Clamp	+45V, -20V		

Table 2.4.5: MForce MicroDrive I/O and Protection Ratings

MForce Standard I/O Connections

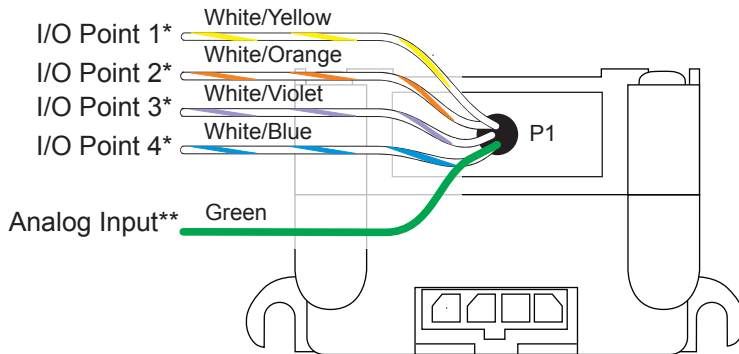

*Sinking or Sourcing Inputs/Sinking Output

** 0 to 5 VDC, 0 to 10 VDC, 0 to 20 mA, 4 to 20 mA, PWM

Figure 2.5.2: Flying Lead I/O Connections

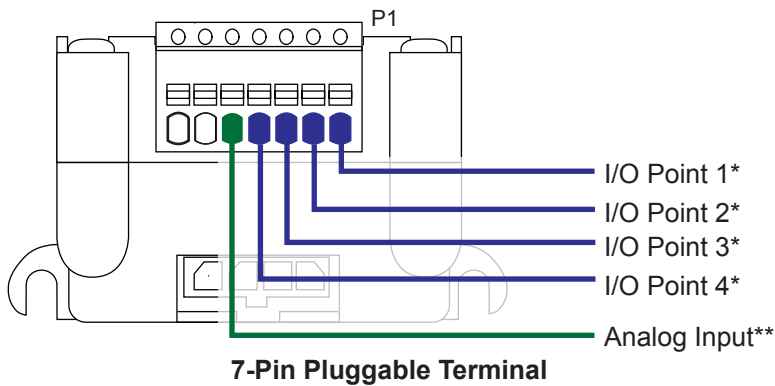

*Sinking or Sourcing Inputs/Sinking Output

** 0 to 5 VDC, 0 to 10 VDC, 0 to 20 mA, 4 to 20 mA

Figure 2.5.3: 7-Pin Pluggable Terminal I/O Connections

MForce Expanded Plus² I/O Connections

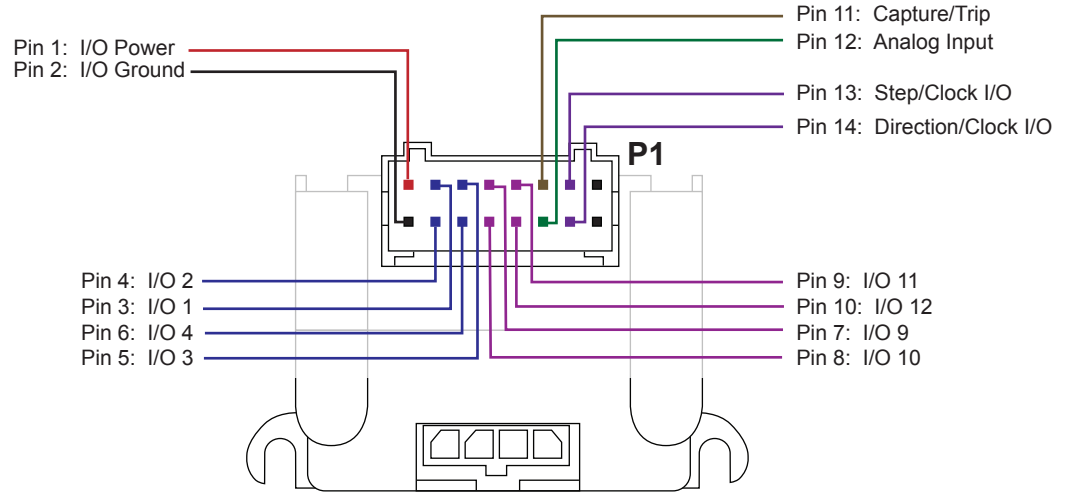

Figure 2.5.4: Plus 2 I/O Connections - Expanded I/O Configuration

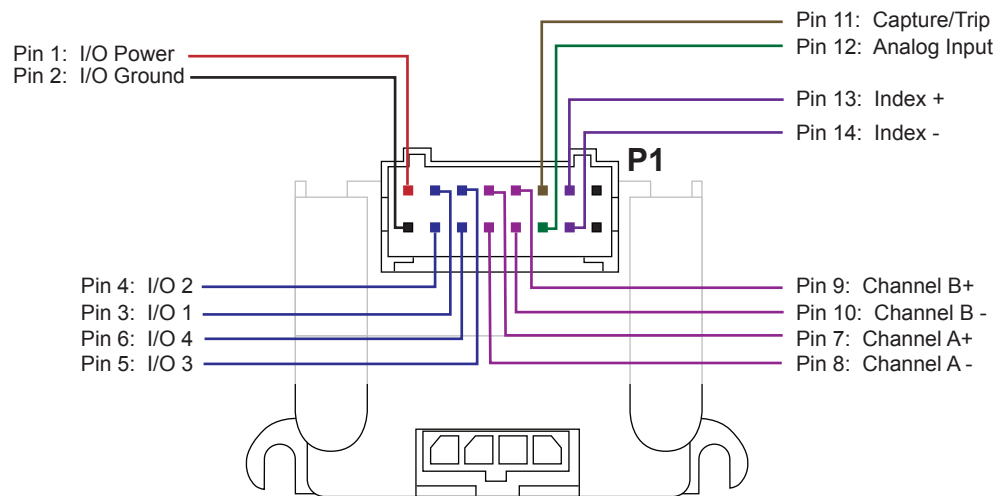

Figure 2.5.5: Plus 2 I/O Connections - Closed Loop Configuration

I/O Usage Examples — MForce MicroDrive Standard I/O Set

The circuit examples below illustrate possible interface examples for using the MForce MicroDrive Digital I/O. Additional diagrams and code snippets are available in Appendix D: I/O Application Guide.

The code samples included with these examples will also serve to introduce the user to MForce MicroDrive programming. Please reference the MForce software manual for more information on the Instructions, Variables and Flags that make up the MForce MicroDrive command set as well as material on setting up and using the IMS Terminal.

Input Interface Example - Switch Input Example (Sinking Input)

The following circuit example shows a switch connected between an I/O point and power ground.

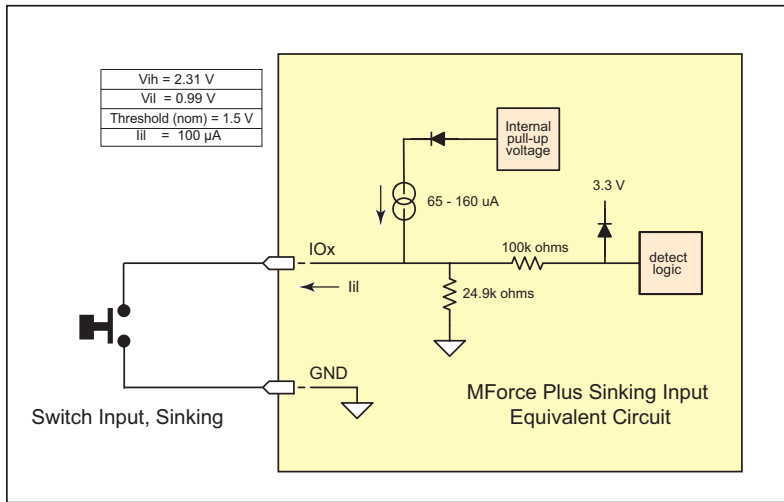

Figure 2.5.6: Sinking Input Example using a Push Button Switch

N NOTE: On the Standard MForce MicroDrive, power ground is used to ground the I/O interface.

N NOTE: Advanced I/O interface circuit diagrams and application examples are available in the I/O Applications Guide Appendix.

Code Sample

For the code sample, this switch will be set up as a G0 sinking input, active when low. When pressed, the switch will launch the program beginning at address1 in MForce memory:

```
***Setup Variables***
Sx=4,0,0      'set IO point x to be a G0 input, active when LOW, sinking

****Program***
PG1
MR 20000      'Move +20000 steps relative to current position
H             'Hold program execution until motion completes
MR -20000     'Move -20000 steps
H             'Hold program execution until motion completes
E
PG            'End program, exit program mode
```

Input Interface Example - Switch Input Example (Sourcing Input)

The following circuit example shows a switch connected between an I/O point and a voltage supply which will source the input to perform a function.

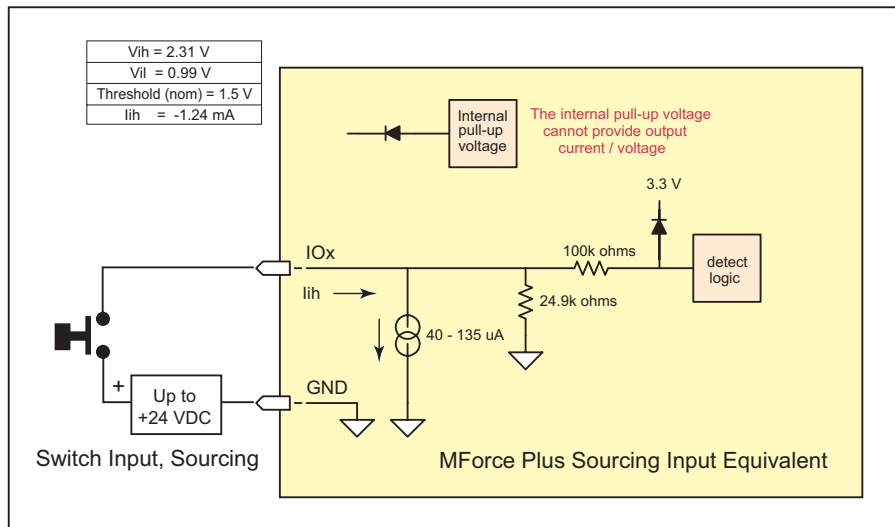

Figure 2.5.7: Sourcing Input Example using a Push Button Switch

Code Sample

For the code sample, the switch will be set up as a Soft Stop sourcing input, active when HIGH. When pressed, the switches will stop the motor.

```
S1=5,1,1      `set IO point 1 to be a Soft Stop input, active when HIGH,  
              `sourcing  
SL 200000     `enter this to slew the motor at 200000  $\mu$ steps/sec
```

When the switch is depressed the motor will decelerate to a stop.

Output Interface Example (Sinking Output)

The following circuit example shows a load connected to an I/O point that will be configured as a sinking output.

NOTE: On the Standard MForce MicroDrive, when configured as outputs, the I/O set is sinking ONLY! The Plus² Models add the functionality of I/O Power, which enables the user to use all the outputs, both Standard and Enhanced, as Sinking or Sourcing.

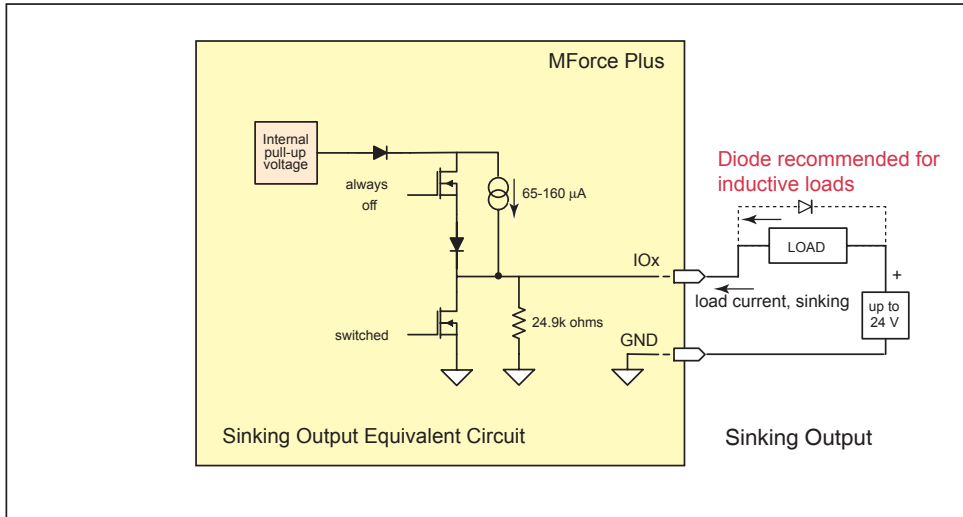

Figure 2.5.8: Sinking Output Example

Code Sample

For the code sample, the load will be an LED. The I/O point will be configured such that the LED will be unlit while the velocity is changing. Use the switch set-up from the previous input, modified to be sinking, example to soft stop the motor.

```
S1=5,0,0    `set IO point 1 to be a Soft Stop input, active when LOW,
            `sinking.
S1=20,0,0   `set IO point 2 to be a Velocity Changing output, active when
            `LOW
SL 2000000  `enter this to slew the motor at 200000 µsteps/sec
```

While the motor is accelerating the LED will be dark, but will light up when the motor reaches a constant velocity. When the Soft Stop switch is depressed the motor will begin to decelerate, the LED will go dark again while velocity is changing.

S1=16,1,0	O1=1 (Sink OFF, Hi-Z)
Output, Active HIGH, Sinking	O1=0 (Sink ON)
S1=16,1,1	O1=1 (Sink ON)
Output, Active LOW, Sourcing	O1=0 (Sink OFF, Hi-Z)



NOTE:
Advanced I/O
interface circuit
diagrams and application
examples are available
in Appendix B: I/O
Application Guide.

General Purpose I/O Usage Examples — Enhanced I/O Set

The Expanded MForce Plus² models add the functionality of either an additional 4 I/O points or an optional interface for a user-defined remote encoder. Additionally, the I/O points, when configured as outputs have the added functionality of being configured as sinking or sourcing outputs.

The circuit examples below illustrate possible interface examples for using the Expanded Digital I/O. Additional diagrams and code samples are available in the I/O Applications Guide appendix.

The code samples included with these examples will also serve to introduce the user to the MCode programming language that is used to operate and program the MForce. Please reference the MCode Programming and Software Reference manual for more information on the Instructions, Variables and Flags that make up the MCode command set as well as material on setting up and using the IMS Terminal.

Input Interface Example - Switch Input Example (Sinking Input)

The following circuit example shows a switch connected between an I/O point and I/O Ground.

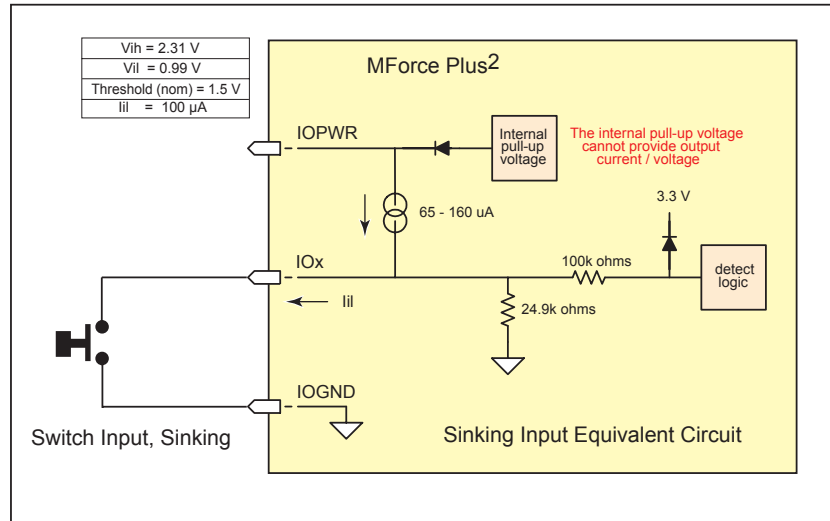

Figure 2.5.9: Switch Interface to Input, Sinking

Code Sample

For the code sample, this switch will be set up as a G0 sinking input, active when low. When pressed, the switch will launch the program beginning at address 1 in MForce memory:

```

***Setup Variables***
Sx=4,0,0      `set IO point x to be a G0 input, active when LOW, sinking

****Program****
PG1
MR 20000      `Move +20000 steps relative to current position
H             `Hold program execution until motion completes
MR -20000     `Move -20000 steps
H             `Hold program execution until motion completes
E
PG            `End program, exit program mode

```

Input Interface Example - Switch Input Example (Sourcing Input)

The following circuit example shows a switch connected between an I/O point and a voltage supply which will source the input to perform a function.

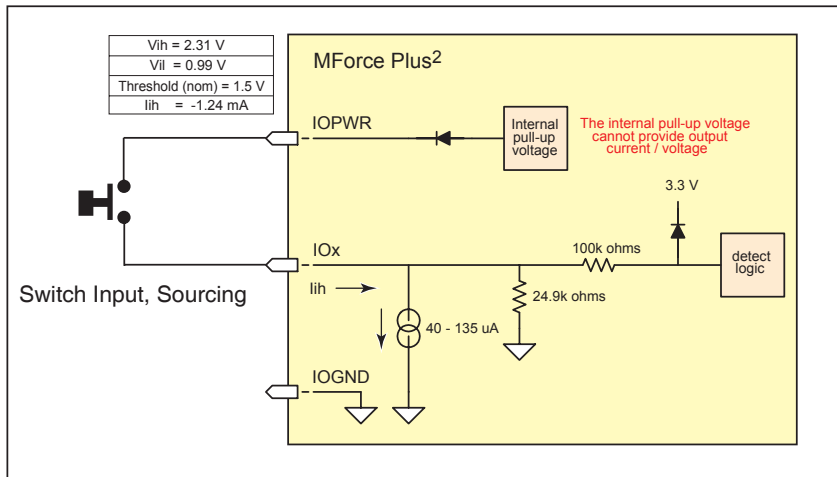

Figure 2.5.10 Sourcing Input Example using a Push Button Switch

Code Sample

For the code sample, the switch will be set up as a Soft Stop sourcing input, active when HIGH. When pressed, the switches will stop the motor.

```
S1=5,1,1    `set IO point 1 to be a Soft Stop input, active when HIGH,
            `sourcing
SL 200000   `enter this to slew the motor at 200000  $\mu\text{steps}/\text{sec}$ 
```

When the switch is depressed the motor will decelerate to a stop.

Output Interface Example (Sinking Output)

The following circuit example shows a load connected to an I/O point that will be configured as a sinking output.

Code Sample

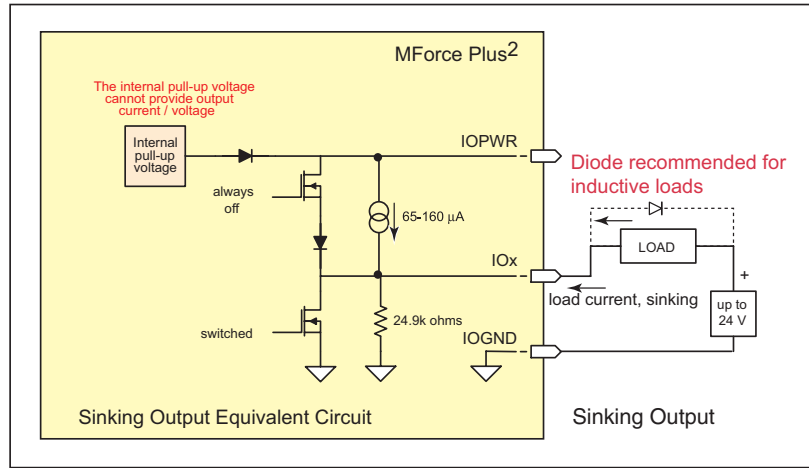

Figure 2.5.11: Sinking Output Example

For the code sample, the load will be an LED. The I/O point will be configured such that the LED will be unlit while the velocity is changing. Use the switch set-up from the previous input, modified to be sinking, example to soft stop the motor.

```

S1=5,0,0      `set IO point 1 to be a Soft Stop input, active when LOW,
              `sinking.
S1=20,0,0     `set IO point 2 to be a Velocity Changing output, active
              `when LOW
SL 2000000    `enter this to slew the motor at 200000 µsteps/sec
    
```

While the motor is accelerating the LED will be dark, but will light up when the motor reaches a constant velocity. When the Soft Stop switch is depressed the motor will begin to decelerate, the LED will go dark again while velocity is changing.

S1=16,1,0 Output, Active HIGH, Sinking	O1=1 (Sink OFF, Hi-Z)
	O1=0 (Sink ON)
S1=16,1,1 Output, Active LOW, Sourcing	O1=1 (Sink ON)
	O1=0 (Sink OFF, Hi-Z)

Output Interface Example (Sourcing Output)

The following circuit example shows a load connected to an I/O point that will be configured as a sourcing output.

Code Sample

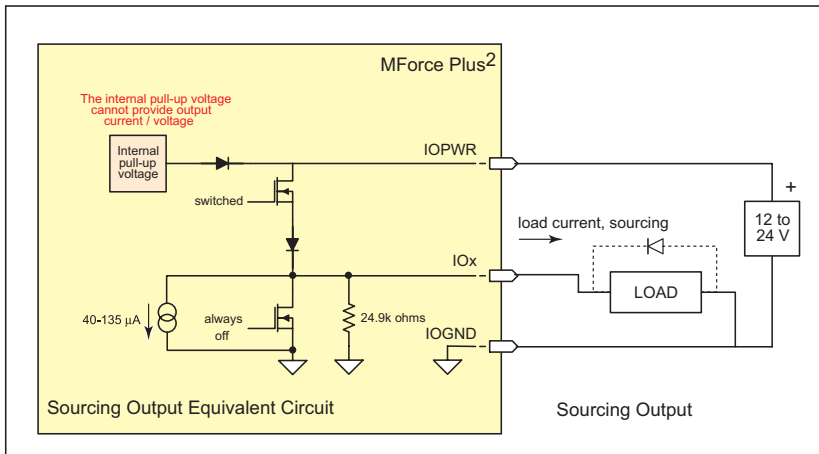

Figure 2.5.12: Sourcing Output Example

For the code sample, the load will be a relay. The output will be configured to be a General Purpose user output that will be set active when a range of motion completes.

```

*****Setup Variables*****
S1=16,1,1    'set IO point 1 to be a user output, active when HIGH,
              'sourcing.

*****Program*****
PG 100      'Enter program at address 100
MR 2000000  'Move some distance in the positive direction
H           'Hold execution until motion completes
MR -1000000 'Move some distance in the negative direction
H           'Hold execution until motion completes
O1=1        'Set output 1 HIGH
    
```

Enter EX 100 to execute the program, the motion will occur and the output will set high.

S1=16,1,1	O1=1 (Source ON)
Output, Active HIGH, Sourcing	O1=0 (Source OFF, Hi-Z)
S1=16,0,1	O1=1 (Source OFF, Hi-Z)
Output, Active LOW, Sourcing	O1=0 (Source ON)

N NOTE: Advanced I/O interface circuit diagrams and application examples are available in the I/O Application Guide Appendix.

N NOTE: When using the MForce MicroDrive2 with the external encoder option, the step and direction I/O are not available! These I/O points become Index + and Index -. See the Closed Loop Control Appendix for encoder connection and configuration information.

Dedicated Digital I/O - Enhanced I/O Set

Step/Direction/Clock I/O

These dedicated I/O lines are used to receive clock inputs from an external device or provide clock outputs to an external device such as a counter or a second MForce MicroDrive a system. The Clock I/O can be configured as one of three clock types using the S7 and S8 variable:

1. Step/Direction
2. Quadrature
3. Up/Down

Step/Direction

The Step/Direction function would typically be used to receive step and direction instructions from a second system MForce or secondary controller. When configured as outputs the MForce can provide step and direction control to another system drive for electronic gearing applications.

Quadrature

The Quadrature clock function would typically be used for following applications where the MForce would either be a master or slave in an application that would require two MForce MicroDrives to move the same distance and speed.

Up/Down

The Up/Down clock would typically be used in a dual-clock direction control application, or to increment/decrement an external counter.

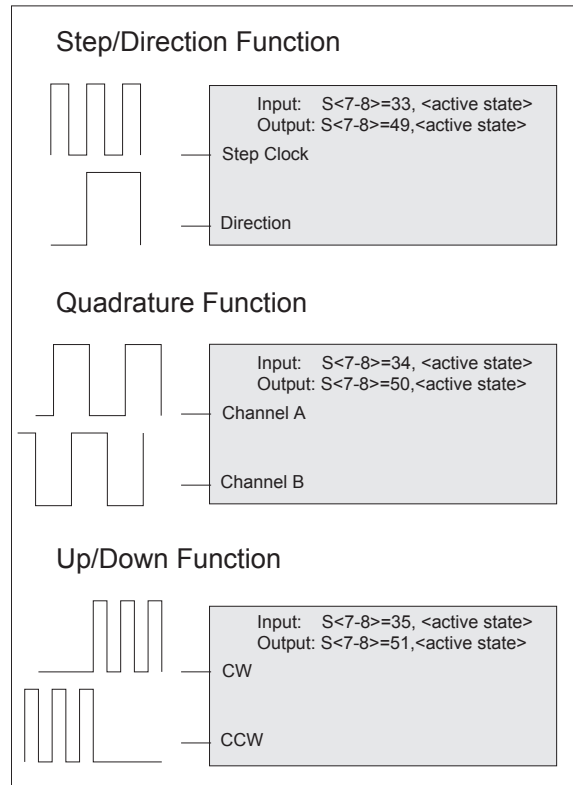

Figure 2.5.13: MForce MicroDrive Clock Functions

WARNING: The Clock I/O and Capture/Trip I/O are TTL Level compatible. DO NOT Exceed +5VDC!

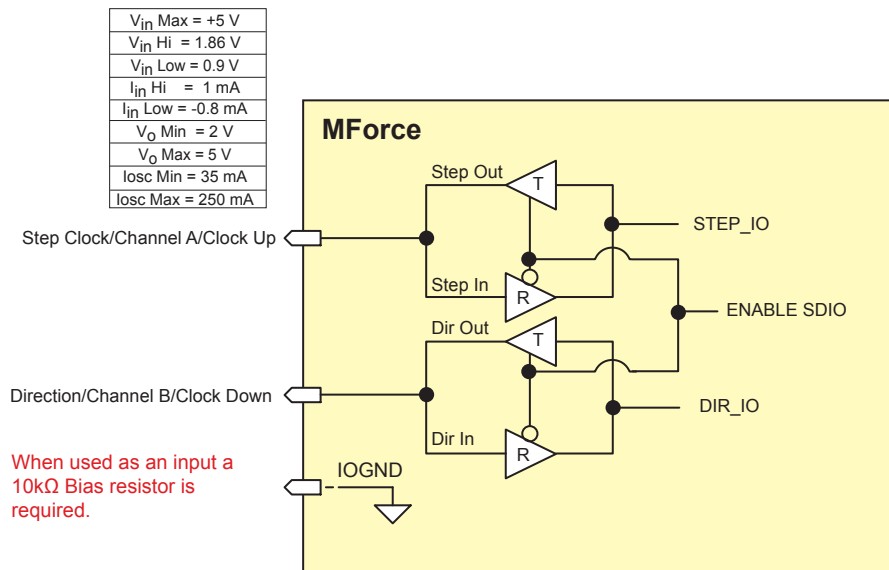

Figure 2.5.14: Step Direction I/O Equivalent Circuit

Capture/Trip

The Capture Input/Trip Output point is a high speed I/O point which can be used for time critical events in motion applications.

Capture Input

When configured as a capture input I/O point 13 has programmable filtering with a range of 50nS to 12.9 μ S and has a resolution of 32 bits. The capture input needs to be pulled up to TTL using a 10k ohm resistor.

To configure the Capture input

```
S13=60,<0/1> `configure IO13 as a capture input, <active HIGH/LOW>  
FC <0-9>      `set input filtering to <range>
```

Trip Output

When configured as a trip output I/O 13 trip speed is 150 nS with 32 bit resolution.

To configure the Trip output

```
S13=61,<0/1> `configure IO13 as a trip output, <active HIGH/LOW>  
CW=10        `set the trip output pulse width to 500 ns
```

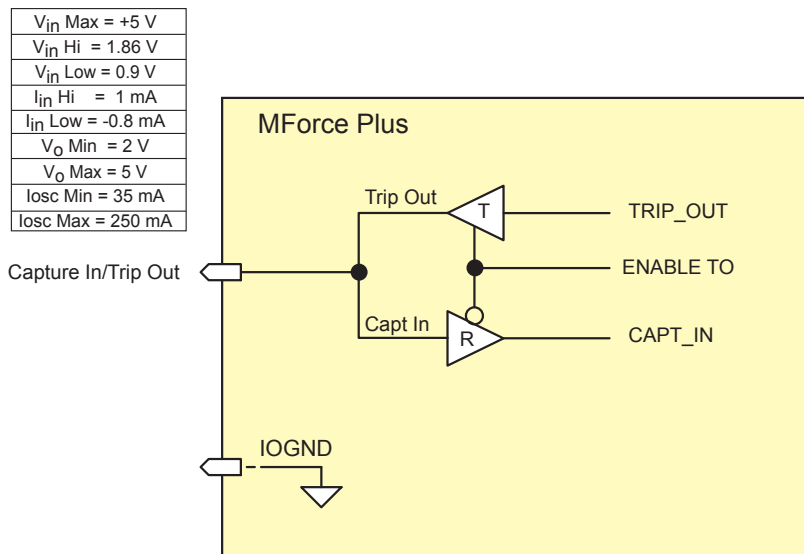

Figure 2.5.15: Capture/Trip I/O Equivalent Circuit

Interfacing the Analog Input

The analog input of the MForce MicroDrive is configured from the factory as a 0 to 5V, 10 bit resolution input (S5=9). This offers the user the ability to receive input from temperature, pressure, or other forms of sensors, and then control events based upon the input.

The value of this input will be read using the I5 instruction, which has a range of 0 to 1023, where 0 = 0 volts and 1024 = 5.0 volts. The MForce MicroDrive may also be configured for a 4 to 20 mA or 0 to 20 mA Analog Input (S5 = 10).

Sample Usage

```
*****Main Program*****  
  
S5=9,0      'set analog input to read variable voltage (0 to +5VDC)  
PG 100     'start prog. address 100  
LB A1      'label program A1  
CL A2, I5<500 'Call Sub A2, If I5 is less than 500  
CL A3, I5>524 'Call Sub A3, If I5 is greater than 524  
BR A1      'loop to A1  
  
*****Subroutines*****  
  
LB A2      'label subroutine A2  
MA 2000 'Move Absolute 2000 steps  
H          'Hold program execution until motion ceases  
RT        'return from subroutine  
  
LB A3      'label subroutine A3  
MA -2000  'Move Absolute -2000 steps  
H          'Hold program execution until motion ceases  
RT        'return from subroutine  
E          'End  
PG        'Exit program
```

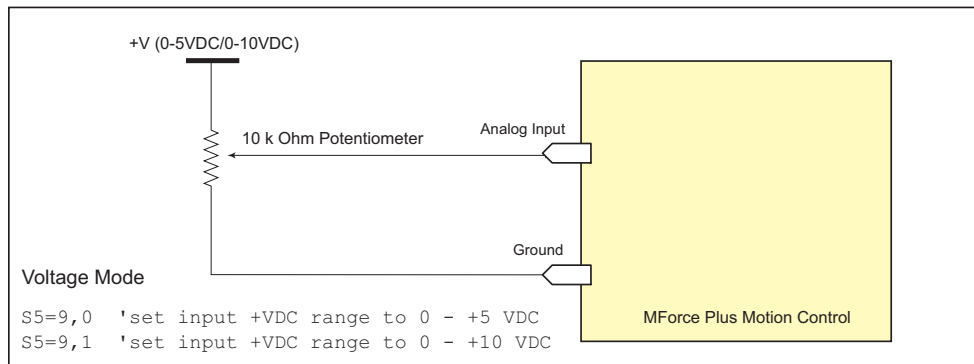

Figure 2.5.16: Analog Input - Voltage Mode

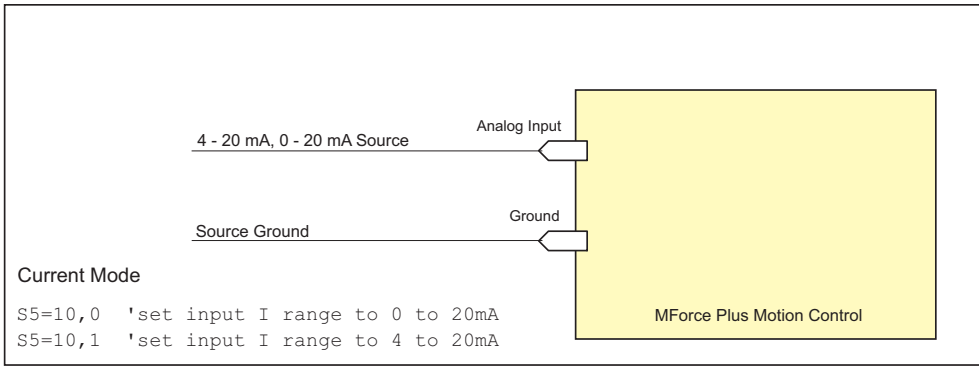

Figure 2.5.17: Analog Input - Current Mode

This Page Intentionally Left Blank



APPENDICES

- Appendix A: CANopen Option
- Appendix B: I/O Application Guide
- Appendix C: Optional IMS Encoders
- Appendix D: Connectivity
- Appendix E: IMS Enhanced Torque Stepping Motors

This Page Intentionally Left Blank

Features

- CANopen DS-301 and DS-402
- Galvanically Isolated Communications
- 3 Dynamically Mappable Process Data Objects (PDO)
- Layer Setting Services to Establish Node ID and BAUD
- Node Guarding
- Heartbeat Producer
- Emergency Objects
- Upgradable Software



NOTE: All other Specifications such as power and I/O are identical to the MForce PowerDrive Motion Control with RS-422/485 Communications Interface.

The CANopen Model MForce PowerDrive may not have all of the features/functionality of its equivalent MForce PowerDrive Motion Control, such as the ability to store programs or I/O functions.

Communications Specifications

Communications Specifications	
Protocol	CAN 2.0b
Communications Profile	CiA DS-301
Device Profile	CiA DSP-402
BAUD Rate	10, 20, 50, 125, 250, 500, 800
Note: 800 kbps not supported by the MD-CC500-000 USB to CANopen dongle.	kBits/s, 1MBit/s (default)

Table D.1: CANopen Communications Specifications



NOTE: See the IMS DSP-402 Application Manual for supported objects and modes of operation.

Interfacing The CAN Bus

The MForce PowerDrive CANopen communicates using the CAN 2.0B Active Protocol and the CiA DS-301 Application Layer and Communications Profile. The full DS-301 V4.02 Specification may be downloaded free at <http://www.can-cia.org>. The default BAUD rate is 1 Mbit/Sec. The default Node ID is 41_h.

CAN Bus Connections

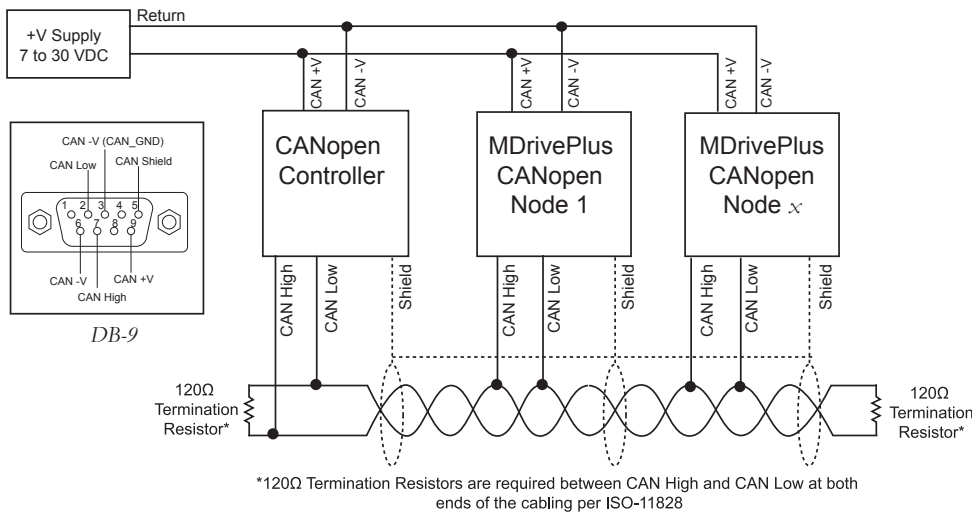

Figure D.1: CANopen Network using MForce PowerDrive.

Pin Assignments

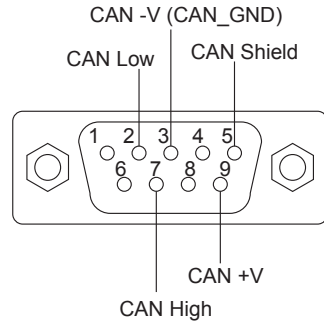

Figure D.2: DB-9 Pin Configuration

P2 Connector - CAN Communications		
DB9	Function	Description
Pin 1	N/C	No Connect
Pin 2	CAN LOW	CAN_L bus line (dominant low)
Pin 3	CAN -V	CAN Communications Ground
Pin 4	AUX-Logic	Auxiliary Logic Supply
Pin 5	CAN Shield	Optional CAN Shield
Pin 6	CAN -V	Optional Ground
Pin 7	CAN HIGH	CAN_H bus line (dominant high)
Pin 8	N/C	No Connect
Pin 9	CAN +V	+7 to +30 VDC supply

Table D.2: DB-9 Pin Assignments and Description

Recommended CANopen Dongle

In order to use the IMS GUI and upgrade utility for the MForce PowerDrive CANopen you must purchase the MD-CC500-000 Communications Cable. When purchased from IMS, the User Interface software for upgrading and prototyping is included. This is required to upgrade the firmware in the MForce PowerDrive as CANopen updates become available.

This device is also available from Phytex at: <http://www.phytex.com/can/hardware/pccaninterface/peakusb.htm>, but does not include the IMS CANopen GUI and Upgrader software.

N NOTE: The MD-CC500-000 USB to CAN Adapter is required to upgrade the firmware in the MForce PowerDrive with CANopen. Any CAN adapter/Controller can be used to communicate to the device using CANopen Objects and Indexes.

Interface Cable Construction

To connect the MD-CC500-000 dongle to the MForce PowerDrive CANopen product an interface cable will need to be constructed. The figure below shows the parts required.

Installation Instructions

1. Install the MD-CC500-000 adapter per the Phytex PCAN-USB Operating Instructions included on the PEAK CD included with the product.
2. Install the IMS CANopen_Tester Interface available online at <http://www.imshome.com/canopen.html>
3. Using the interface cable (not supplied), connect the MForce PowerDrive product to the MD-CC500-000.
4. Apply Power to the MForce PowerDrive CANopen product.

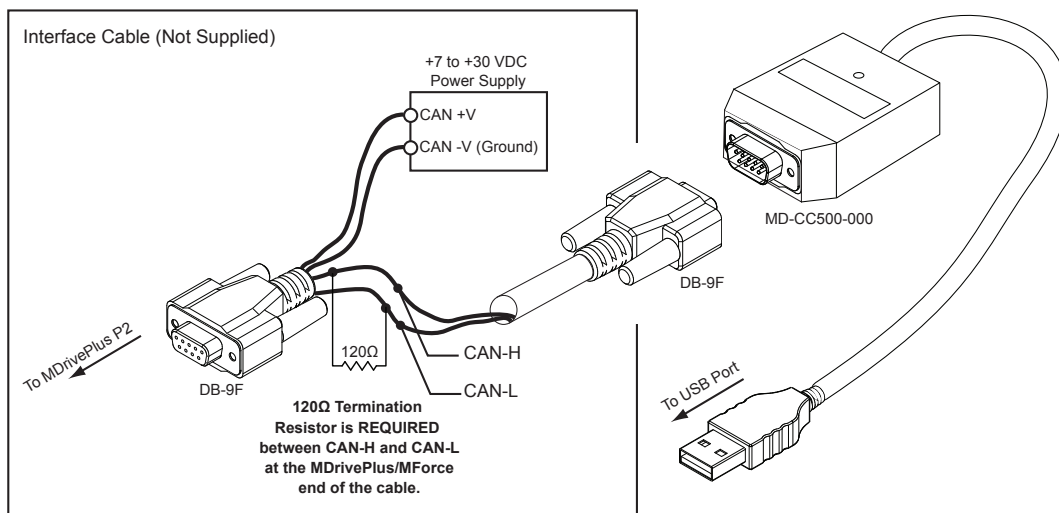

DB-9F

9-Pin D-Sub Connector Front View

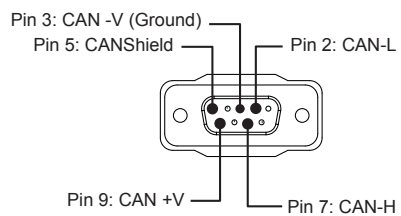

Figure D.3: MD-CC500-000 and Interface Cable.

CANopen Tester Quick Start

Installation

1. Open the CANopen CD using Windows Explorer.
2. Browse to the CANopen_Tester Folder.
3. Double-Click the Setup.exe file.
4. Follow the prompts to install the program.

To ensure you have the latest version of the IMS CANopen Tester, please visit the IMS web site at <http://www.imshome.com/canopen.html>.

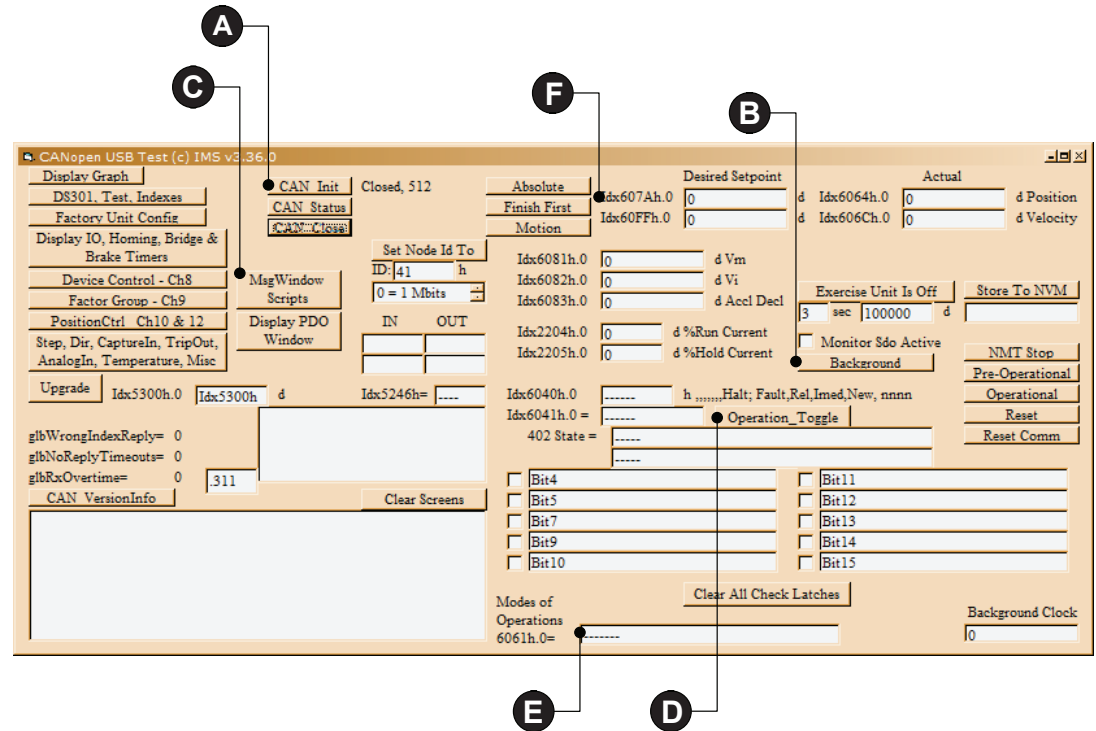

Figure D.4: CANopen Tester Interface Showing Getting Started Sequence

Getting Started

The below instructions are for IMS CANopen products being used with IMS's MD-CC500-000, USB to CANopen communication, and the IMS CANopen Tester software. Use the illustration above to follow along with the usage steps. This getting started will step the user from initializing the CAN bus to moving the motor in Profile Position mode.

Before applying power and launching software.

- 1) Install PEAK Drivers from CD
- 2) Run Setup.exe from IMS CD
- 3) Connect power according to CANopen Hardware Reference Manual, Section 2.2 - Connecting Power.
- 4) Connect communication according to this appendix.

You can now power the MForce or MForce product and launch the CANopen Tester software.

With the MForce or MForce powered and the CANopen Tester software launched, select through the following sequence.

- A. Click CAN Init
- B. Click Background – Background Clock should start running and data fields should be populated with current Index values.
- C. Click Msg Window Scripts – This will open another window to allow the user to see data being sent to MForce or MForce in the following steps.

- D. Click Operation_Toggle three times (this steps through Index 0x6040 Control Word ending with Operation Enabled). This enables the output bridge of the driver.
- E. Enter the number “1” in the Modes of Operations field, this places the MForce into Profile Position mode.
- F. Enter 512000 into the IDX67AH field, strike the return (Enter) key on your key board, the motor should move 10 revolutions.

This Page Intentionally Left Blank

Standard I/O Set Interfacing and Application

NPN Sinking Input

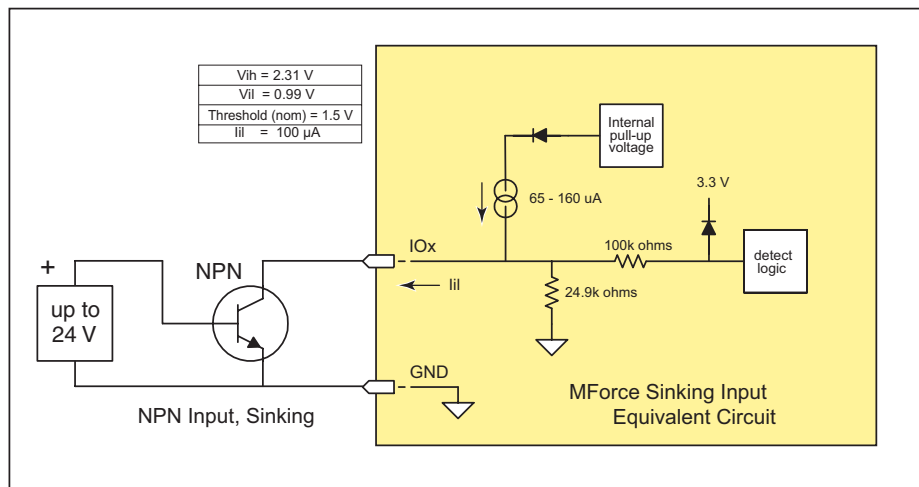

Figure B.1: NPN Interface to an MForce Sinking Input

Proximity sensor will operate as a +Limit. When active LOW will index the motor to a specified position.

```

\ [VARIABLES]
S1=2,0,0          'set IO1 to Limit+, Active LOW, sinking
\ [PROGRAMS]
PG 100            'enter program mode at address 100
LB AA             'label program AA
MR 200000000     'move relative x distance
H                'hold program execution until move completes
CL AB , I1 = 0   'call subroutine AB if I1 = 0 (limit reached)
BR AA , I1 = 1   'branch to AA if I1=1
LB AB            'Label Sub AB
PR "Error 83, Positive Limit Reached"
ER=0
MA - 10000      'Absolute move to Pos. -10000
H                'hold program execution until move completes
E                'end program
PG              'exit program.
\ [END]
    
```

PNP Sourcing Input

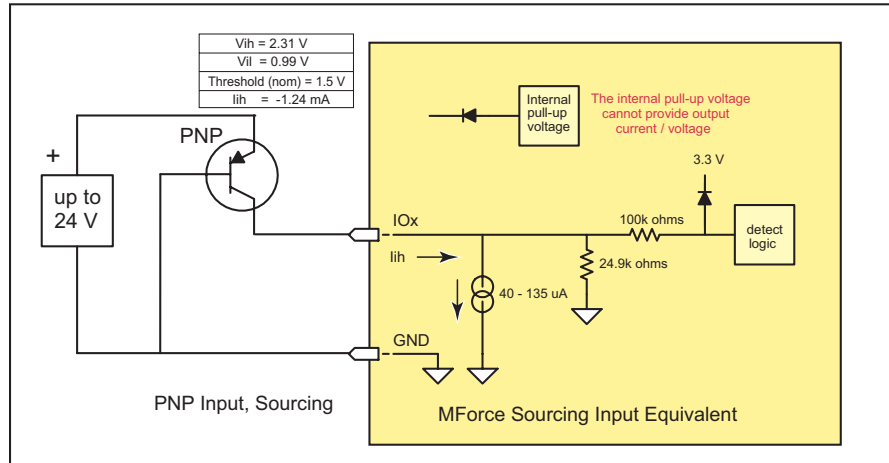

Figure B.2: PNP Interface to a Sourcing Input

Application Example

Will use this input as a general purpose input which will run a motion subroutine when HIGH.

```

\ [VARIABLES]
S1=0,1,1          \set IO1 Gen Purpose User, active HIGH, src
S2=0,1,1          \set IO2 Gen Purpose User, active HIGH, src
\ [PROGRAMS]
\*****Main Program*****
PG 100
LB AA
    CL SA,I1=1     \call sub SA if IO1=1
    CL SB,I2=1     \call sub SB if IO2=1
    BR AA
\*****Subroutines*****
LB SA              \Subroutine will perform some motion
    MR 200000
    H
    MR -200000
    H
    BR SA,I1=1     \conditional branch to beginning of sub
    BR AA,I1=0     \Branch to main program if IO1=0
    RT
LB SB              \Subroutine will perform some motion
    MR 10000
    H
    MR -10000
    H
    BR SB,I2=1     \conditional branch to beginning of sub
    BR AA,I2=0     \Branch to main program if IO1=0
    RT
E
PG
\ [END]

```

Sinking Output

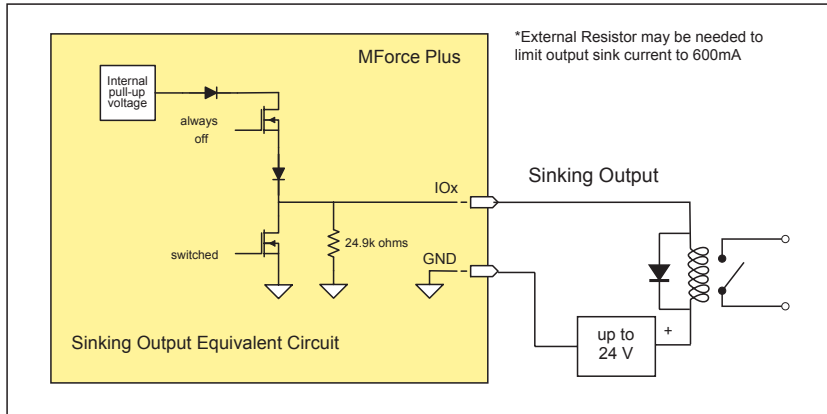

N NOTE: On the Standard MForce Plus, when configured as outputs, the I/O set is sinking ONLY! The Plus² Models add the functionality of I/O Power, which enables the user to use all the outputs, both Sinking or Sourcing.

Figure B.3: Sinking Output to Relay

Application Example

Active LOW Output will be open a relay, useful for Fault.

```
`[VARIABLES]
S1=19,0,0           `Configure IO 1 as a Fault output.
```

Mixed Input/Output Example

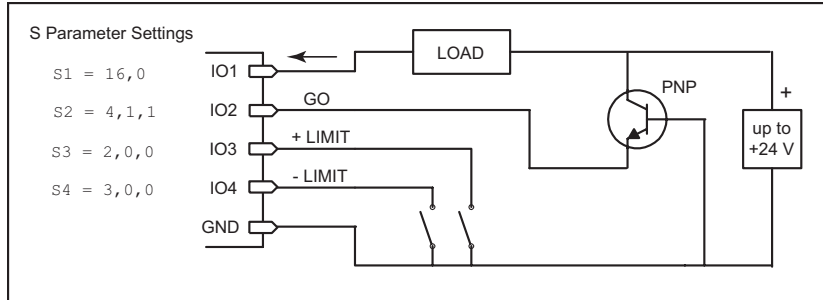

Figure B.4: Mixed Output Example- Standard I/O Set

Enhanced I/O Set Interfacing and Application

NPN Sinking Input

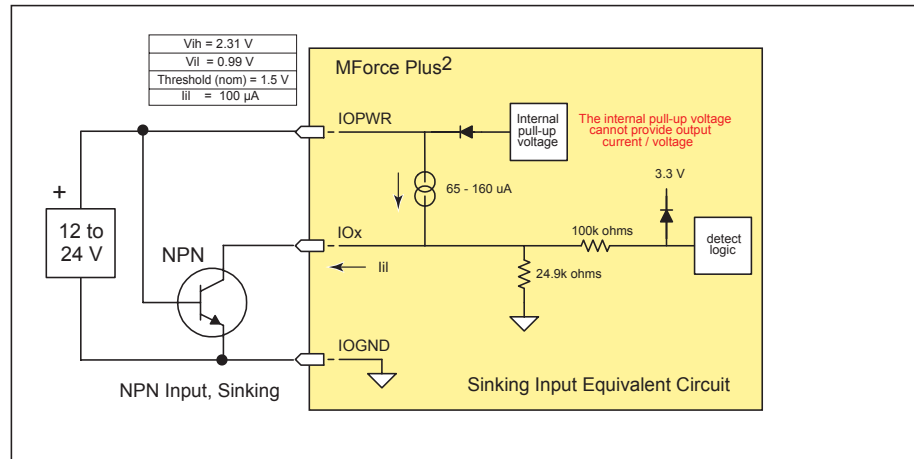

Figure B.5: NPN Sinking Input on an MForce Plus² Motion Control

Application Example

Sensor using the HOME function.

```
\[VARIABLES]
S2=1,1,0           `Configure IO2 as a Home Input, active HIGH, sinking.

Enter to IMS Terminal in Immediate mode or in a Program

HM 1               `Slew at VM - until IO2 = 1, Creep off + at VI
```

PNP Sourcing Input

Application Example

Sensor using the Jog+ function.

```
JE=1               `Enable Jog function
```

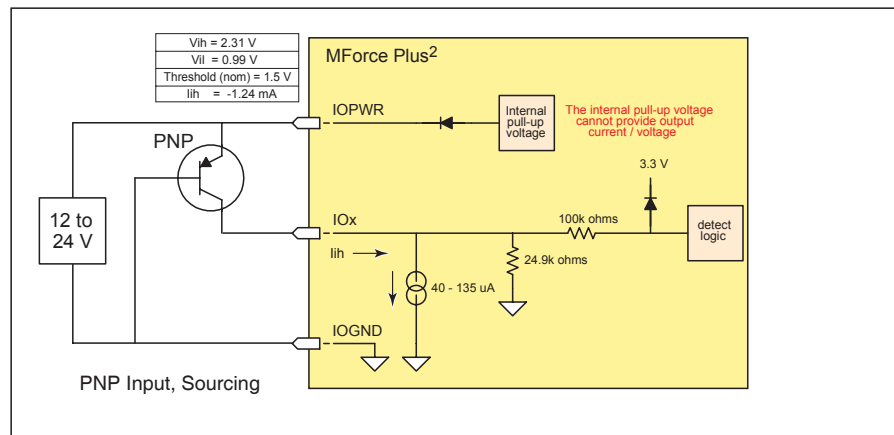

Figure B.6: PNP Sourcing Input on an MForce Plus² Motion Control

```
S11=7,1,1         `Configure IO11 as a Jog+ Input, active HIGH, sourcing
```

Sourcing Output

Application Example

This application example will illustrate two MForce Plus2 units in a system. In the program example MForce Plus2 #1 will be configured as a Fault Output, which when HIGH will trip an input on MForce Plus2 #2 which will be configured as a Pause Input.

MForce #1

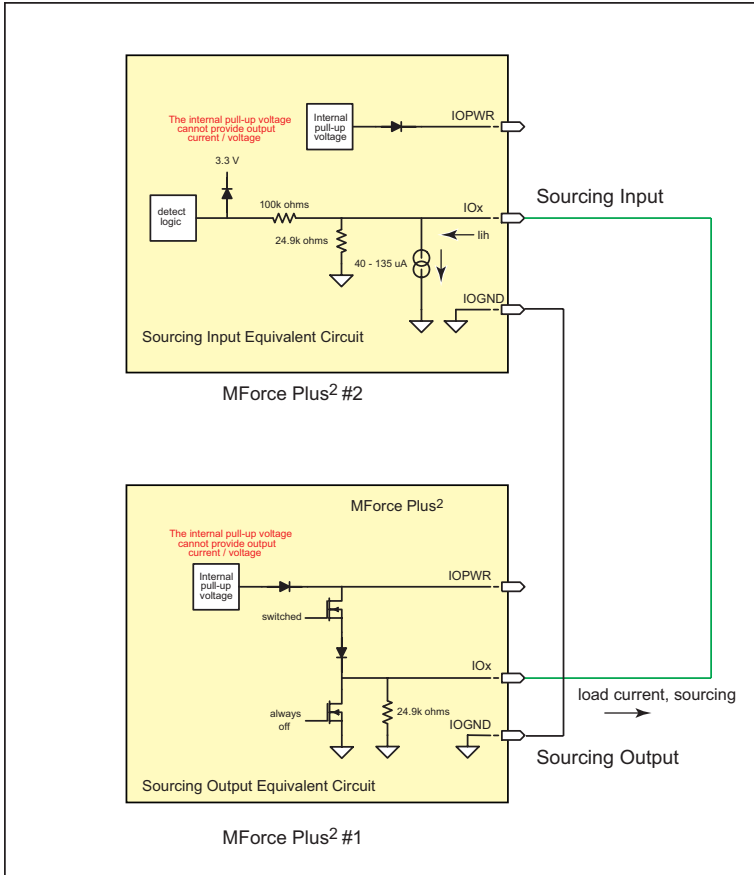

Figure B.7: Sourcing Output to Sourcing Input

```
S9=18,1,1      `Configure IO9 as a Fault output, active HIGH, sourcing
```

```
MForce #2  
S9=6,1,1      `Configure IO9 as a Pause Input, active HIGH, sourcing.
```

Mixed Input/Output Example

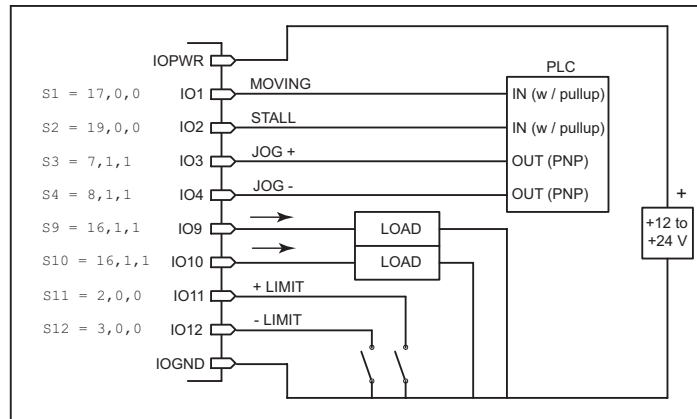

Figure B.8: Mixed Input/Output Example - Enhanced I/O

Interfacing Inputs as a Group Example

The MForce inputs may read as a group using the IL, IH and IN keywords. This will display as a decimal between 0 to 15 representing the 4 bit binary number (IL, IH) or as a decimal between 0 and 255 representing the 8 bit binary number on the MForce Plus² models. The IN keyword will function on the standard MForce but will only read inputs 1 - 4. Inputs will be configured as user inputs (S<point>=0).

Standard MForce Plus Motion Control

```
PR IN      `Reads Inputs 4 (MSB) through 1 (LSB)
PR IN      `Reads Inputs 4 (MSB) through 1 (LSB)
```

Enhanced MForce Plus²

```
PR IL      `Reads Inputs 4 (MSB) through 1 (LSB)
PR IH:     `Reads Inputs 12 (MSB) through 9 (LSB)
PR IN:     `Reads Inputs 12 (MSB) - 9 and 4 - 1 (LSB)
```

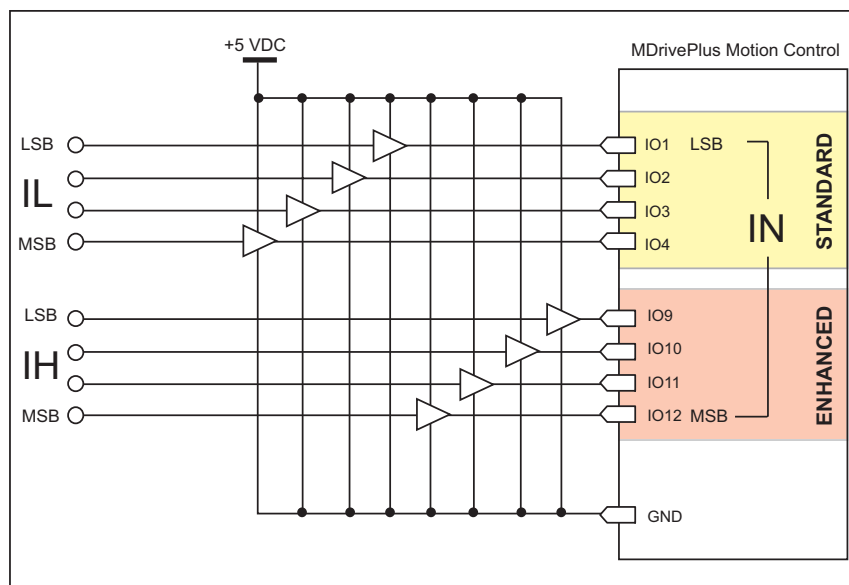

Figure B.9: TTL Interface to an Input Group

Interfacing Outputs as a Group Example

The MForce inputs may be written to as a group using the OL, OH and OT keywords. This will set the outputs as a binary number representing the decimal between 0 to 15 representing the 4 bit binary number (OL, OH) or as an 8 bit binary number representing the decimal 0 to 255 on the Expanded MForce Plus² models. The OT keyword will function on the standard MForce but will only set inputs 1 - 4. Outputs will be configured as user outputs (S<point>=16).

Standard MForce Plus Motion Control

```
OL=3      `set the binary state of the standard I/O to 0011
OT=13    `set the binary state of the standard I/O to 1101
```

Enhanced MForce Plus2

```
OL=5      `set the binary state of the standard I/O to 0101
OH=9      `set the binary state of the expanded I/O to 1001
OT=223    `set the binary state of the combined I/O to 1101 1111
```

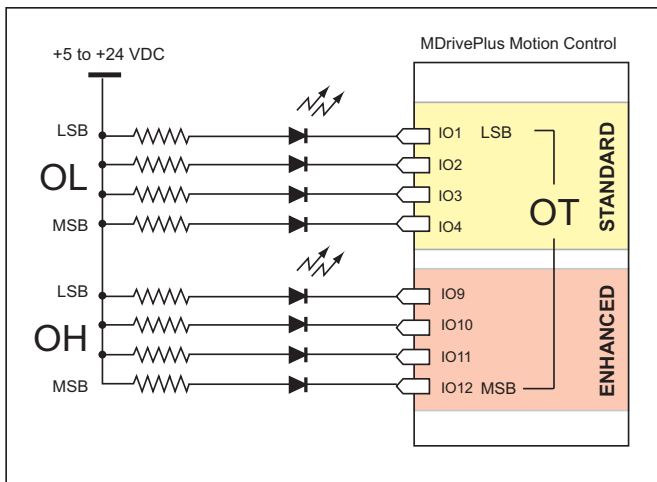

Figure B.10: Outputs Interfaced to LED's as a Group

Output Bit Weight Examples								
I/O Set	Enhanced (Plus ²)				Standard			
	IO12 (MSB)	IO11	IO10	IO9	IO4	IO3	IO2	IO1 (LSB)
OL=13 OT=13	NOT AVAILABLE							
					1	1	0	1
OH=9					NOT ADDRESSED BY OH			
	1	0	0	1				
OT=223								
	1	1	0	1	1	1	1	1

Table B.1: Output Bit Weight Examples - Outputs set as a group

This Page Intentionally Left Blank

MForce Motion Control Closed Loop Options

Remote Differential Encoder - MForce MicroDrive Plus²

The MForce Plus² models are available with the option of using a remote encoder through the enhanced I/O. The advantage of using a remote encoder is that the encoder can be stationed directly on the load for increased accuracy. If ordering with a motor these encoders may be mounted for you at the factory. Only differential encoders may be used with the MForce Plus².

Set Up and Configuration

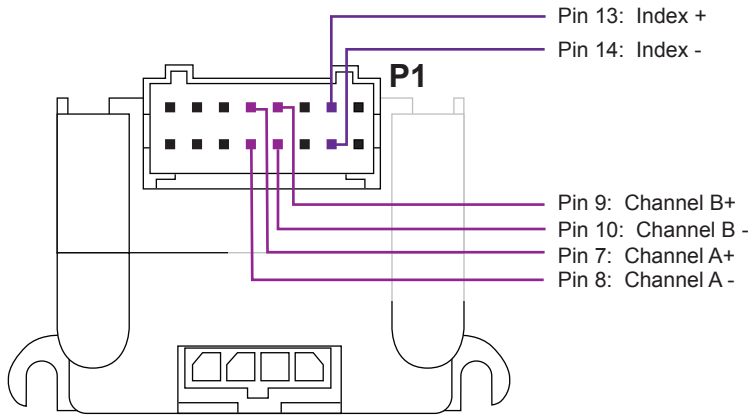
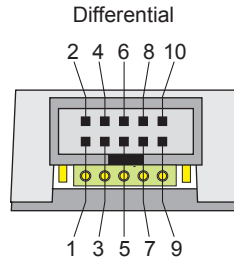

Figure C.1: Connecting a Remote Encoder

Encoders Available from IMS

Line Count	DIFFERENTIAL ENCODER Part Number
100	EA
200	EB
250	EC
256	EW
400	ED
500	EH
512	EX
1000	EJ
1024	EY



Pin 1: No Connect	Pin 6: Channel A +
Pin 2: +5VDC Input	Pin 7: Channel B -
Pin 3: Ground	Pin 8: Channel B +
Pin 4: No Connect	Pin 9: Index -
Pin 5: Channel A -	Pin 10: Index +

Table C.1: Available Encoder Line Counts, Part Numbers and Pin Configurations

General Specifications

	Min	Typ	Max	Units
Supply Voltage (VDC)	-0.5		7	Volts
Supply Current	30	57	85	mA
Output Voltage	-0.5		V _{cc}	Volts
Output Current (Per Channel)	-1.0		5	mA
Maximum Frequency				100kHz
Inertia		0.565 g-cm ²	(8.0 x 10 ⁻⁶ oz-in-sec ²)	

Temperature	
Operating	-40 to +100° C
Storage	-40 to +100° C
Humidity	90% (non-condensing)

Encoder Signals

Differential Encoder

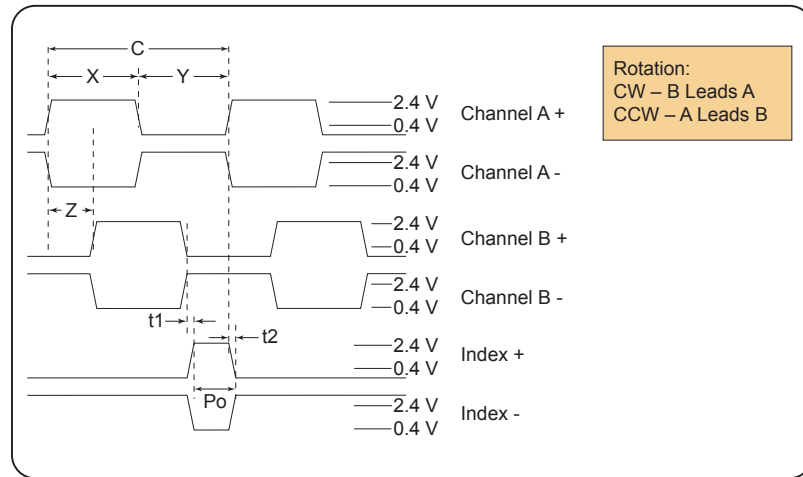

Figure C.2: Differential Encoder Signals

Note: Rotation is as viewed from the cover side.

- (C) One Cycle: 360 electrical degrees (°e)
- (X/Y) Symmetry: A measure of the relationship between X and Y, nominally 180°e.
- (Z) Quadrature: The phase lag or lead between channels A and B, nominally 90°e.
- (Po) Index Pulse Width: Nominally 90°e.

Characteristics

Parameter	Symbol	Min	Typ	Max	Units
Cycle Error		3		5.5	°e
Symmetry		130	180	230	°e
Quadrature		40	90	140	°e
Index Pulse Width	Po	60	90	120	°e
Index Rise After CH B or CH A fall	t1	-300	100	250	ns
Index Fall After CH A or CH B rise	t2	70	150	1000	ns

Over recommended operating range. Values are for worst error over a full rotation.

Encoder Cables

IMS Differential Encoder Cable (36" leads) ED-CABLE-2

Recommended Encoder Mating Connectors

IMS recommends the following mating connectors (or equivalent) if you make your own cables.

Differential Encoder

Tyco Electronics Connector with 10 Preloaded IDC Pins*	102694-3
Shell with Polarizing Key	102537-3
Back Cover	102536-3
Tyco Electronics 10 Pin IDC Ribbon Cable Connector	499997-1
3M 28 AWG x 0.5 x 10 Conductor Ribbon Cable	3365/10

*For AWG 22 to 28 wires.

This Page Intentionally Left Blank

WARNING! DO NOT connect or disconnect the Communications Converter Cable from MForce while power is applied!

MD-CC40x-001 Communications Cable

The MD-CC40x-001 is an in-line USB to RS-422/4895 converter with attachable cable to interface with the MForce MicroDrive P2 Communications connector. The included components will allow you to connect the USB port of a PC directly to the MForce Motion Control. The converter will automatically detect if RS422 or RS485 is being used and configure itself accordingly

There are three variations of this cable, which can be used with the different P2 connector variations of the MForce MicroDrive:

1. MD-CC400-001 USB to 10-Pin IDC connector.
2. MD-CC402-001 USB to 10-Pin Friction Lock Wire Crimp Connector. Note that this cable also has an optional prototype development cable available to interface to multiple MForces for party mode communications. Part Number PD10-1430-FL3.

The MD-CC40x-001 communications converter cable is designed to be used with all MForce, MForce MicroDrive and MForce MicroDrive Motion Control devices that utilize an RS-422/485 interface.

Supplied Components: MD-CC40x-001 Communications Converter, Drive Interface Cable, USB Cable, USB Drivers, IMS Terminal Interface Software.

Electrical Specifications

MD-CC40x-001 Specifications	
BAUD Rate	Up to 115 kbps
Power Requirement	Power from USB

Table D.1: MD-CC40x-001 Electrical Specifications

MD-CC400-001 Mechanical Specifications and Connector Details

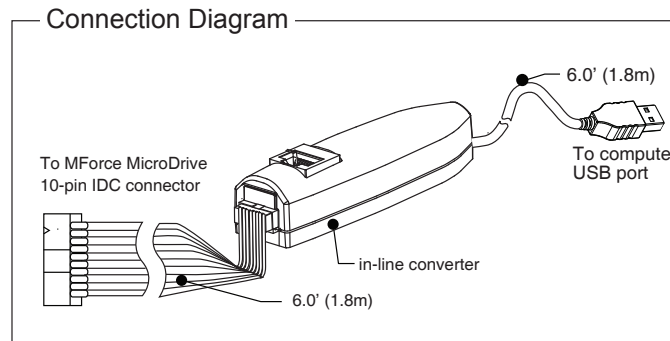
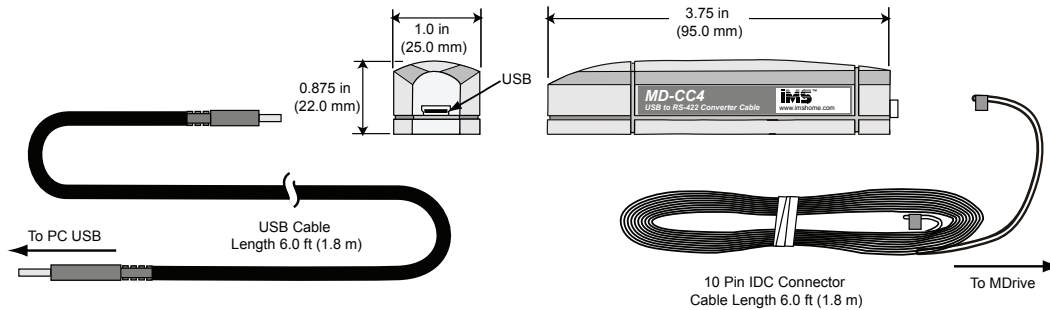

Figure D.1: MD-CC400-001 Mechanical Specifications and Connection

Connector Detail and Mating Connector Kit

Should you choose to create your own interface cable IMS now has mating connector kits available which assist you in creating interface cables in small quantities. These kits come with the connector shells and crimp pins (if applicable) to create five interface cables.

Connector Details

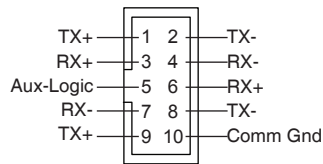

Figure D.2: 10-Pin IDC

Mating Connector Kit p/n: CK-01

Description: 5 mating connector shells for making interface cables to MForce's 10-pin IDC connector. 2-piece connector shell crimps onto a 10 conductor AMP ribbon cable. Ribbon Cable is not included.

IDC Parts: Shell: SAMTEC TCSD-05-01-N
Ribbon Cable: AMP 1-57051-9

Using the MD-CC400-001 in MultiDrop Configuration

Required: MD-CC400-001 USB to RS-422 Communications Converter
Mating Connector Kit CK-01 or equivalent

1. Crimp the required number of IDC connectors on the ribbon cable. If additional length is required, cable extenders are available from SAMTEC or an interface ribbon cable may be made to the length required. (IMS recommends not exceeding 15' cable length with ribbon cable).
2. Remove the ground conductor (Pin 10) between all connectors except the connector for the first MForce in the daisy chain. This is to prevent communication errors and and potential damage due to ground loops. See Figure D.3

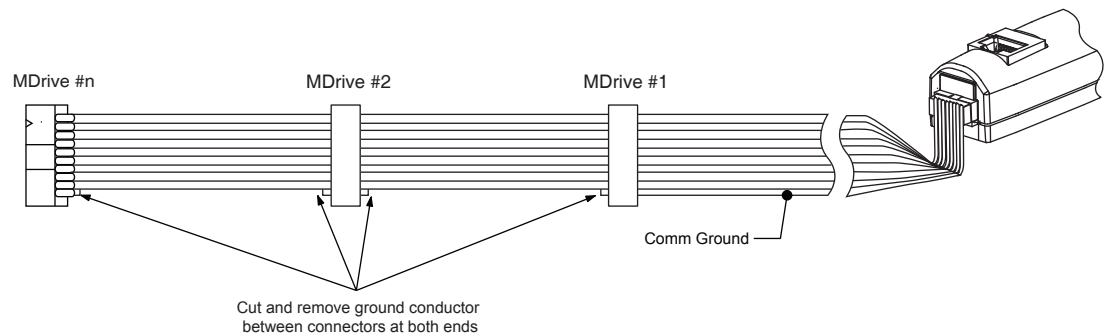

Figure D.3: Configuring the MD-CC400-001 for Multi-drop (Party Mode) Communications

MD-CC402-001 Mechanical Specifications and Connection

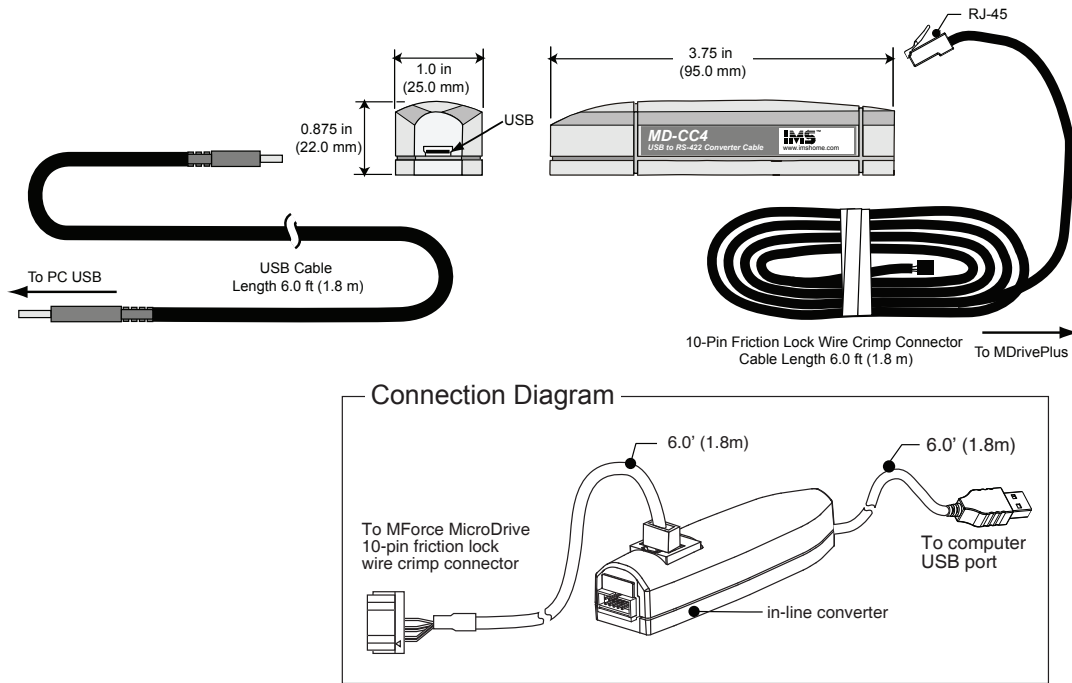

Figure D.4: MD-CC402-000 Mechanical Specifications and Connection

Connector Detail and Mating Connector Kit

Should you choose to create your own interface cable IMS now has mating connector kits available which assist you in creating interface cables in small quantities. These kits come with the connector shells and crimp pins to create five interface cables.

Connector Details

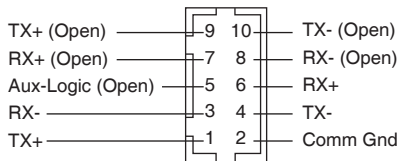

Figure D.5: 10-Pin Wire Crimp

Pins 5-10 are left open to facilitate use of the PD10-1434-FL3 for multi-drop communications and connection of Aux-Logic.

Mating Connector Kit p/n: CK-02

Description: 5 mating connector shells and crimp pins. Recommend Hirose Crimp tool (Not included).

Hirose Parts: Shell: DF11-10DS-2C
Pins: DF11-2428SC
Crimp Tool: DF11-TA2428HC

PD-10-1434-FL3 and MD-CC402-001 in MultiDrop Configuration

Required: MD-CC402-001 USB to RS-422 Communications Converter
 Prototype Development Cable PD10-1434-FL3

1. Connect crimp pins into the appropriate connector locations on the 10-pin wire crimp that are left open on the MD-CC402-001 for this purpose.
2. Remove the ground conductor (Pin 10) between all connectors except the connector for the first MForce in the daisy chain. This is to prevent communication errors and and potential damage due to ground loops. See Figure D.6

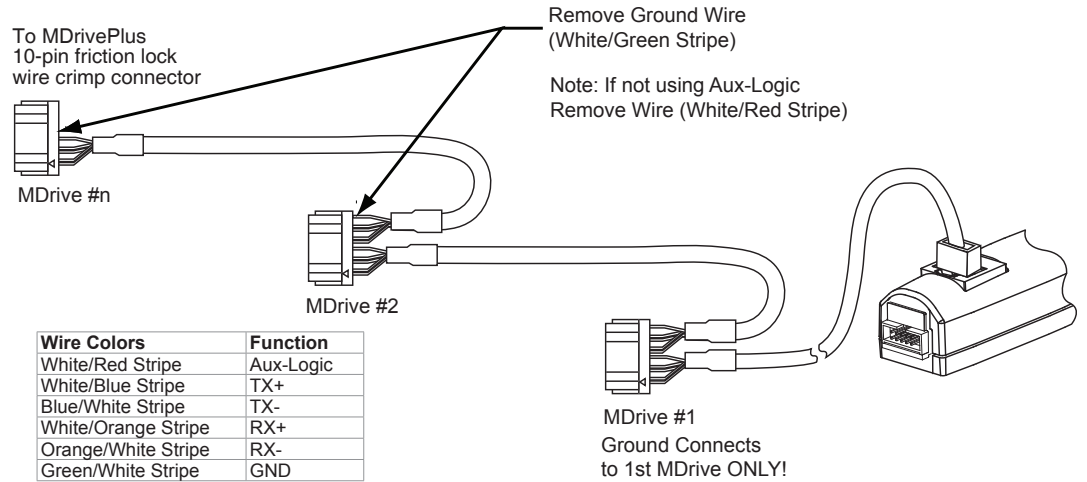

Figure D.6: Configuring the MD-CC402-001 for Multi-drop (Party Mode) Communications

Installation Procedure for the MX-CC40x-000

These Installation procedures are written for Microsoft Windows XP Service Pack 2. Users with earlier versions of Windows please see the alternate installation instructions at the IMS web site (<http://www.imshome.com>).

The installation of the MD-CC40x-001 requires the installation of two sets of drivers:

- Drivers for the IMS USB to RS-422 Converter Hardware.
- Drivers for the Virtual Communications Port (VCP) used to communicate to your IMS Product.

Therefore the Hardware Update wizard will run twice during the installation process.

The full installation procedure will be a two-part process: Installing the Cable/VCP drivers and Determining the Virtual COM Port used.

Installing the Cable/VCP Drivers

Before beginning installation, download the drivers from http://www.imshome.com/cable_drivers.html and extract to a location on your hard drive.

- 1) Plug the USB Converter Cable into the USB port of the MD-CC40x-001.
- 2) Plug the other end of the USB cable into an open USB port on your PC.
- 3) Your PC will recognize the new hardware and open the Hardware Update dialog.
- 4) Select “No, not this time” on the radio buttons in answer to the query “Can Windows Connect to Windows Update to search for software?” Click “Next” (Figure D.7).



Figure D.7: Hardware Update Wizard

- 5) Select “Install from a list or specific location (Advanced)” on the radio buttons in answer to the query “What do you want the wizard to do?” Click “Next” (Figure D.8).
- 6) Select “Search for the best driver in these locations.”
 - (a) Check “Include this location in the search.”
 - (b) Browse to the location of the extracted driver files.
 - (c) Click Next (Figure D.9).

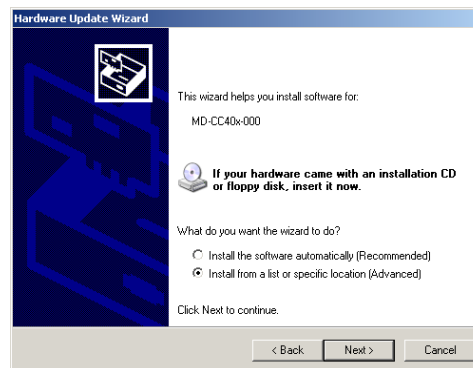

Figure D.8: Hardware Update Wizard Screen 2

- 7) The drivers will begin to copy.
- 8) On the Dialog for Windows Logo Compatibility Testing, click “Continue Anyway” (Figure D.10).
- 9) The Driver Installation will proceed. When the Completing the Found New Hardware Wizard dialog appears, Click “Finish” (Figure D.11).
- 10) Upon finish, the Welcome to the Hardware Update Wizard will reappear to guide you through the second part of the install process. Repeat steps 1 through 9 above to complete the cable installation.

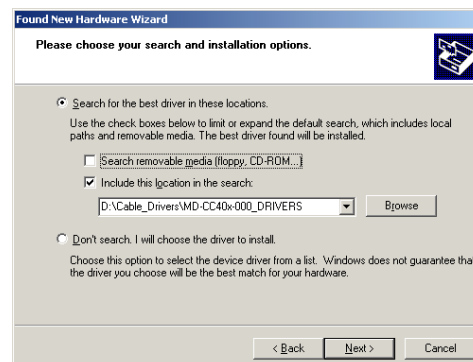

Figure D.9: Hardware Update Wizard Screen 3

- 11) Your IMS MD-CC402-001 is now ready to use.



Note: An Interactive Tutorial covering the installation of the Cable/VCP drivers are located on the IMS Web Site at <http://www.imshome.com/tutorials.html>.

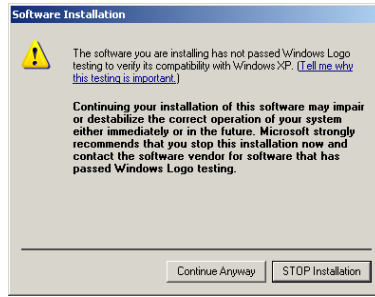

Figure D.10: Windows Logo Compatibility Testing



Figure D.11: Hardware Update Wizard Finish Installation

Determining the Virtual COM Port (VCP)

The MD-CC40x-000 uses a Virtual COM Port to communicate through the USB port to the MForce. A VCP is a software driven serial port which emulates a hardware port in Windows.

The drivers for the MD-CC40x-001 will automatically assign a VCP to the device during installation. The VCP port number will be needed when IMS Terminal is set up in order that IMS Terminal will know where to find and communicate with your IMS Product.

To locate the Virtual COM Port.

- 1) Right-Click the “My Computer” Icon and select “Properties”.
- 2) Browse to the Hardware Tab (Figure D.12), Click the Button labeled “Device Manager”.
- 3) Look in the heading “Ports (COM & LPT)” IMS USB to RS422 Converter Cable (COMx) will be listed (Figure D.13). The COM # will be the Virtual COM Port connected. You will enter this number into your IMS Terminal Configuration.

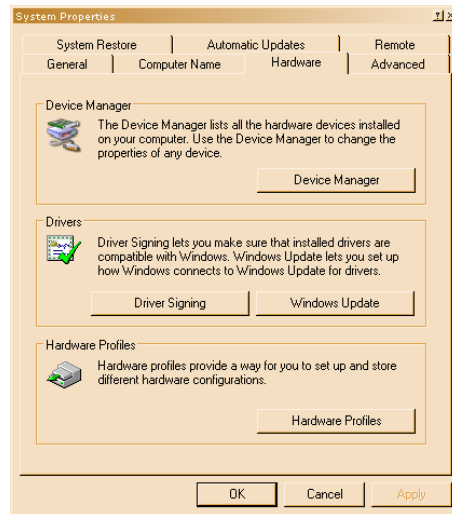

Figure D.12 Hardware Properties

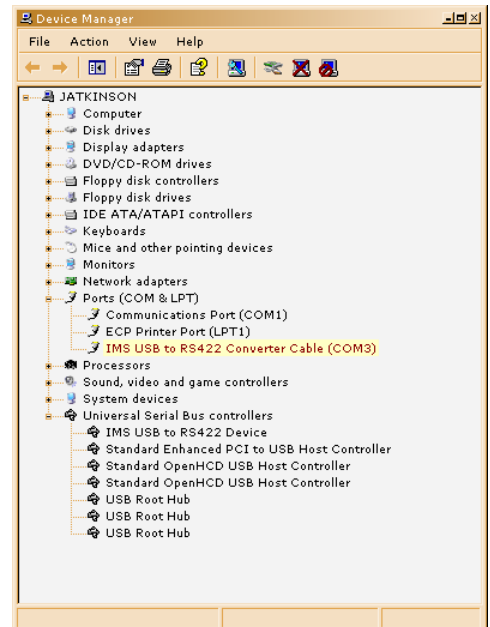

Figure D.13: Windows Device Manager

Prototype Development Cable PD10-1434-FL3 For Multi-Drop Communications

The PD10-1434-FL3 is a 10' (3.0 M) Prototype Development Cable used to connect multi-drop communications to the MForce MicroDrive Motion Control. The Flying Lead End connects to the user's RS-422 Interface. The Connector End connects to the 10-Pin Wire Crimp Connector located at P2 on the MForce.

Setup Instructions — Cable #1

1. Cut crimp pins from Communications Wires and strip insulation back approximately 1/4".
2. Connect receive (RX) and transmit (TX) lines as shown in the diagram and table above to your RS-422/485 Host interface.
3. Connect Communications Ground line to the Comm Ground of your RS-422/485 Host.
4. Connect Aux-Power (if used) to the +VDC Output of a +12 to +24 VDC Supply.
5. Connect the return (GND) of the Aux-Supply to Power Ground of the MForce MicroDrive.
6. Plug the wire crimp connector of Cable #1 into P2 of the MForce MicroDrive #1.

Setup Instructions — Cable #2 and Subsequent MForces

1. Insert the crimped transmit and receive lines into the 10-Pin wire crimp connector of Cable #1 as shown in the diagram and table above.
2. Connect communications ground (May be daisy-chained).
3. Connect Aux-Supply at the +VDC output of the +12 to +24 VDC Supply (May NOT be daisy-chained).
4. Plug the wire crimp connector of Cable #2 into P2 of MForce MicroDrive #2
5. Repeat Steps 1-4 for each additional MForce MicroDrive in the system.

Wire Color Code			
Pair Number (Cable/Pair)	Color Combination	Communications Host Connection	MForce Wire Crimp Connection
1/1	White/Blue	RX+	TX+
	Blue/White	RX+	TX-
1/2	White/Orange	TX+	RX+
	Orange/White	TX-	RX-
1/3	White/Green	NC	NC
	Green/White	COMM GND	COMM GND
2/1	White/Blue	TX+	TX+
	Blue/White	TX-	TX-
2/2	White/Orange	RX+	RX+
	Orange/White	RX-	RX-
2/3	White/Green	NC	NC
	Green/White	COMM GND	COMM GND
3		AUX Power	AUX Power

Table D.2: PD10-1434-FL3 Wire Color Codes



WARNING! DO NOT connect or disconnect the Prototype Development Cables from MForce while power is applied!



WARNING! Ensure that the Black-Color pair is correctly matched prior to power application.

MForce MicroDrive Recommended Prototype Development Cable

P1: PD16-1417-FL3 — Power and I/O

The PD16-1417-FL3 is a 10' (3.0 M) Prototype Development Cable used to connect to the 16-Pin Locking Wire Crimp Connector. The Connector end plugs into the P1 Connector of the MForce MicroDrive. The Flying Lead end connects to a Control Interface such as a PLC and the users motor power supply.

Wire Color Code				
Pair Number	Color Combination	Signal Name (Expanded I/O)	Signal Name (Remote Encoder)	P1 Pin Number
1	Black	Power Ground	Power Ground	16
	Red	+V (+12 to +48 VDC)	+V (+12 to +48 VDC)	15
2	Black	Direction	Index -	14
	White	Step Clock	Index +	13
3	Black	Analog In	Analog In	12
	Green	Capture In/Trip Out	Capture In/Trip Out	11
4	Black	I/O 12	Channel B -	10
	Blue	I/O 11	Channel B +	9
5	Black	I/O 10	Channel A -	8
	Yellow	I/O 9	Channel A +	7
6	Black	I/O 4	I/O 4	6
	Brown	I/O 3	I/O 3	5
7	Black	I/O 2	I/O 2	4
	Orange	I/O 1	I/O 1	3
8	White	I/O GND	I/O GND	2
	Red	I/O Power	I/O Power	1

Table D.3: PD16-1417-FL3 Wire Color Codes

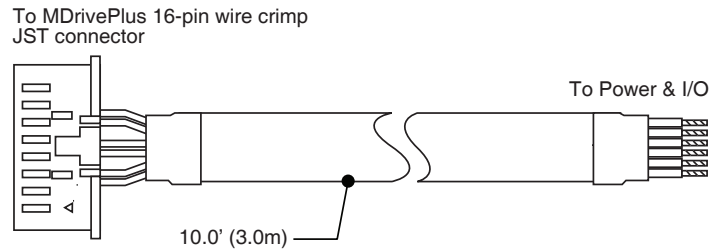

Figure D.14: PD16-1417-FL3 Prototype Development Cable

Connector Detail and Mating Connector Kit

Should you choose to create your own interface cable IMS now has mating connector kits available which assist you in creating interface cables in small quantities. These kits come with the connector shells and crimp pins to create five interface cables.

Connector Details

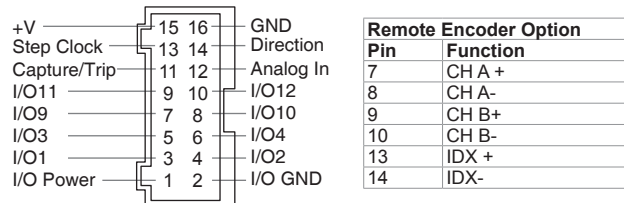

Figure D.15: 16-Pin Wire Crimp

Mating Connector Kit p/n: CK-10

Description: 5 mating connector shells and crimp pins. Recommend JST Crimp tool (Not included).
 JST Parts: Shell: PADP-16V-1-S
 Pins: SPH-001T-P0.5L
 Crimp Tool: YHT2622

Prototype Development Cable PD04-MF34-FL3

The PD04-MF34FL3 is a 10' (3.0 M) Prototype Development Cable used to connect the MForce PowerDrive to a stepping motor. The pairs are numbered.

Wire Color Code			
Pair Number	Color Combination	Signal Name	P1 Pin Number
1	Green	Phase A	2
	White	Phase \bar{A}	1
2	Red	Phase B	4
	Black	Phase \bar{B}	3

Table D.4: PD04-MF34-FL3 Wire Color Codes

To MForce MicroDrive 4-pin wire crimp
Tyco connector

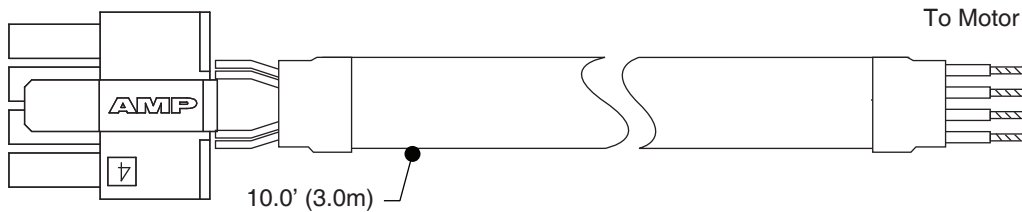

Figure D.16: PD04-MF34-FL3

Connector Detail and Mating Connector Kit

Should you choose to create your own interface cable IMS now has mating connector kits available which assist you in creating interface cables in small quantities. These kits come with the connector shells and crimp pins to create five interface cables.

Connector Details

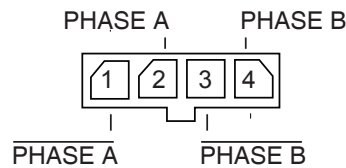

Figure D.17: 4-Pin Wire Crimp

Mating Connector Kit p/n: CK-05

Description: 5 mating connector shells and crimp pins. Recommend Molex Crimp tool (Not included).

Tyco Parts: Shell: 1445022-4
Pins: 1-794610-1
Crimp Tool: 91501-1

This Page Intentionally Left Blank

Size 14 Enhanced Torque Stepping Motor

General Specifications

Part Number	Holding Torque	Phase Current	Number of Leads	Phase Resistance	Phase Inductance	Detent Torque	Rotor Inertia	L _{Max} Length	Weight
	oz-in (N-cm)	Amps		ohms	mH		oz-in (N-cm)	oz-in-sec ² (kg-cm ²)	
M-1410-0.75[X]*	10 (7)	0.75	4	4.3	4	1.4 (1.0)	0.00017 (0.012)	1.02 (26)	4.2 (120)

Table E.1: Size 14 General Specifications

Wiring And Connection

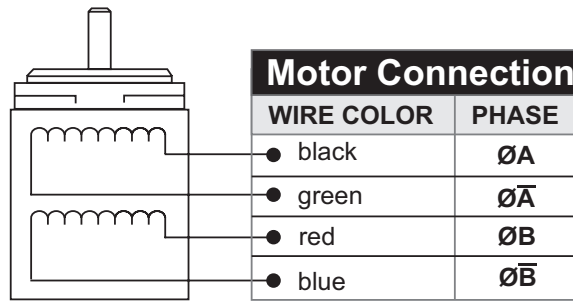

Figure E.1: Size 14 Wiring and Connection

Mechanical Specifications

Dimensions in Inches (mm)

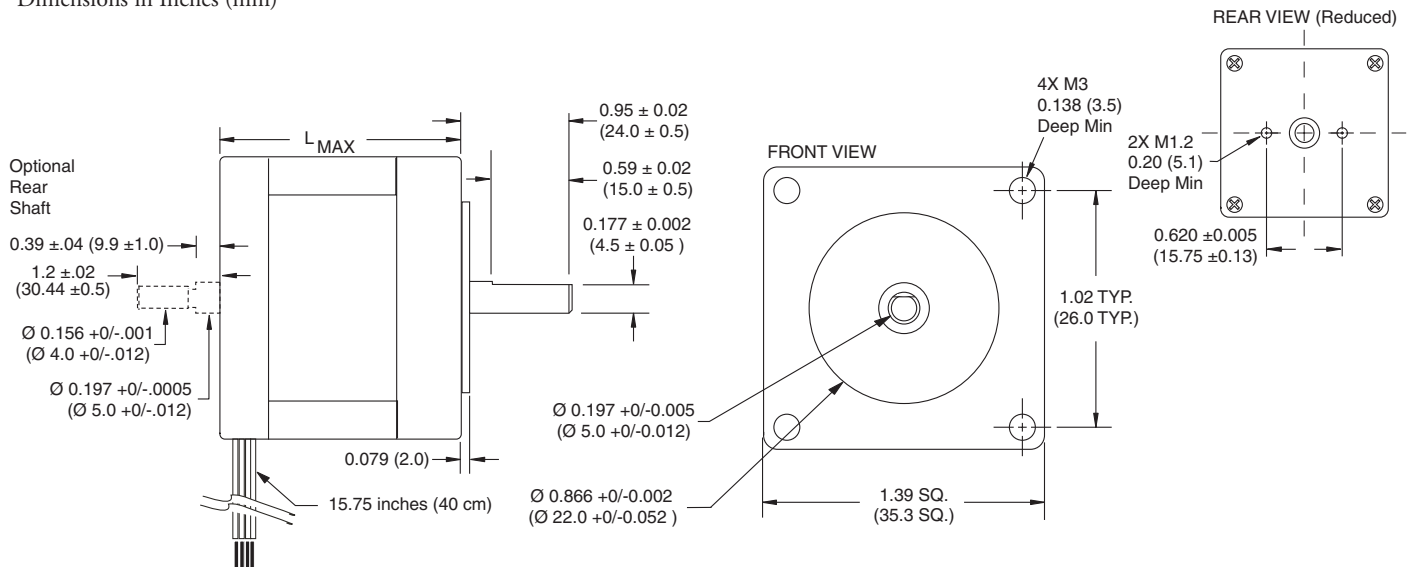

Figure E.2: Size 14 Mechanical Specifications

Size 17 Enhanced Torque Stepping Motor

General Specifications

Part Number	Holding Torque	Phase Current	Number of Leads	Phase Resistance	Phase Inductance	Detent Torque	Rotor Inertia	LMax Length	Weight
	oz-in (N-cm)	Amps		ohms	mH	oz-in (N-cm)	oz-in-sec ² (kg-cm ²)	inches (mm)	
M-1713-1.5[X]*	32 (23)	1.5	4	1.3	2.1	1.7 (1.2)	0.000538 (0.038)	1.34 (34)	7.4 (210)
M-1715-1.5[X]*	60 (42)	1.5	4	2.1	5.0	2.1 (1.5)	0.0008037 (0.057)	1.57 (40)	8.1 (230)
M-1719-1.5[X]*	75 (53)	1.5	4	2.0	3.85	3.5 (2.5)	0.0011562 (0.082)	1.89 (48)	12.7 (360)

*Specify S for Single Shaft; D for Double Shaft

Table E.2: Size 17 General Specifications

Wiring And Connection

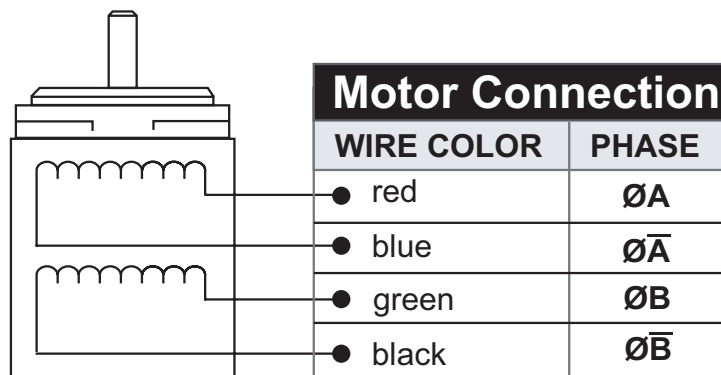

Figure E.3: Size 17 Wiring and Connection

Mechanical Specifications

Dimensions in Inches (mm)

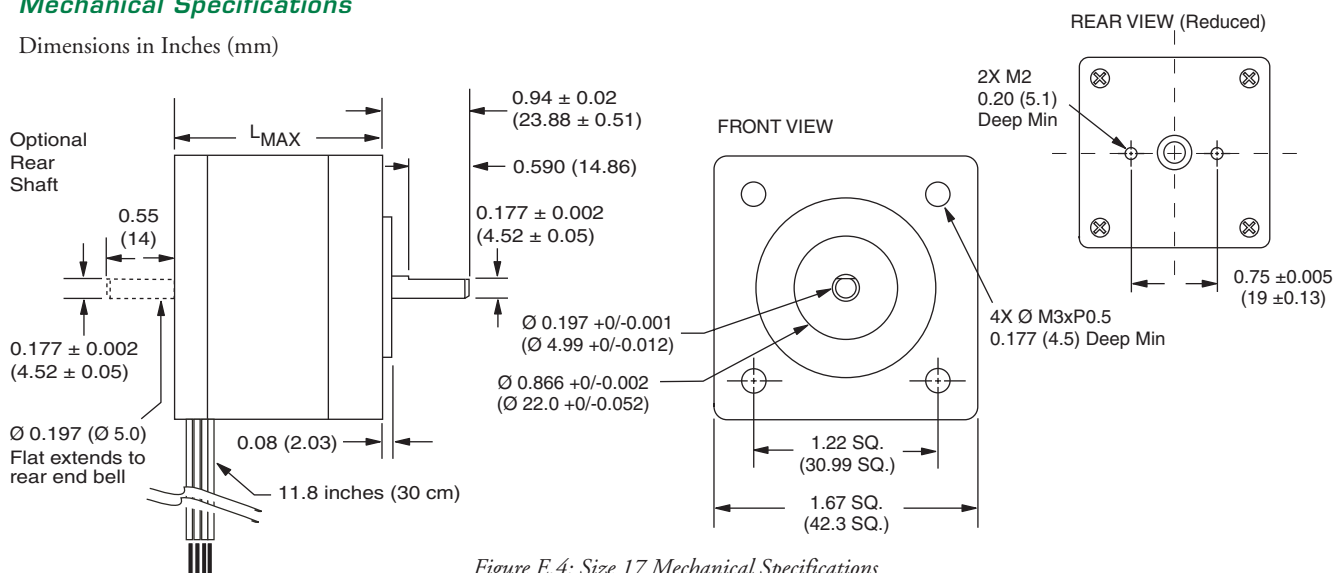

Figure E.4: Size 17 Mechanical Specifications

Size 23 Enhanced Torque Stepping Motor

General Specifications

Part Number	Holding Torque oz-in (N-cm)	Phase Current Amps	Number of Leads	Phase Resistance ohms	Phase Inductance mH	Detent Torque oz-in (N-cm)	Rotor Inertia oz-in-sec ² (kg-cm ²)	L _{Max} Length inches (mm)	Weight oz (g)
2.4 Amp: M-2218-2.4S	90 (64)	2.4	4	0.95	2.4	3.9 (2.7)	0.00255 (0.18)	1.77 (45)	16.9 (480)
2.4 Amp: M-2222-2.4S	144 (102)	2.4	4	1.2	4.0	5.6 (3.9)	0.00368 (0.26)	2.13 (54)	21.2 (600)
2.4 Amp: M-2231-2.4S	239 (169)	2.4	4	1.5	5.4	9.7 (6.9)	0.0065 (0.46)	2.99 (76)	35.3 (1000)

*Specify S for Single Shaft; D for Double Shaft

Table E.3: Size 23 General Specifications

Wiring And Connection

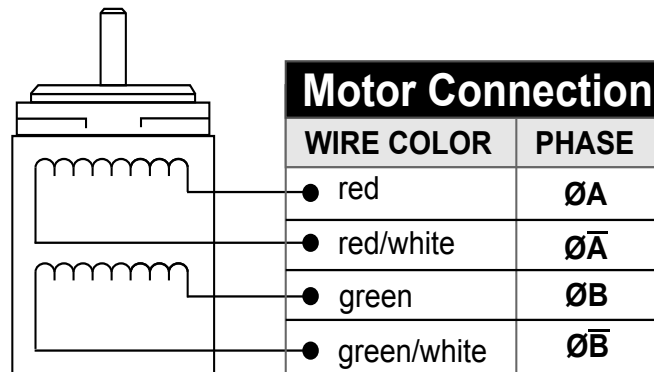

Figure E.5: Size 23 Wiring and Connection

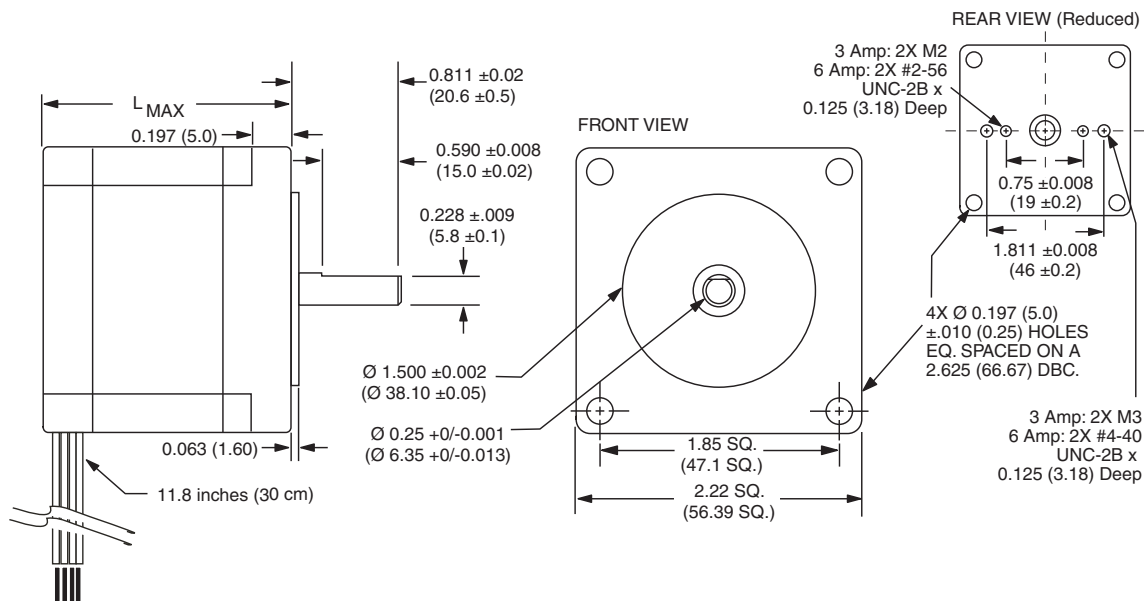

Figure E.6: Size 23 Mechanical Specifications

This Page Intentionally Left Blank

WARRANTY

TWENTY-FOUR (24) MONTH LIMITED WARRANTY

Intelligent Motion Systems, Inc. ("IMS"), warrants only to the purchaser of the Product from IMS (the "Customer") that the product purchased from IMS (the "Product") will be free from defects in materials and workmanship under the normal use and service for which the Product was designed for a period of 24 months from the date of purchase of the Product by the Customer. Customer's exclusive remedy under this Limited Warranty shall be the repair or replacement, at Company's sole option, of the Product, or any part of the Product, determined by IMS to be defective. In order to exercise its warranty rights, Customer must notify Company in accordance with the instructions described under the heading "Obtaining Warranty Service."

This Limited Warranty does not extend to any Product damaged by reason of alteration, accident, abuse, neglect or misuse or improper or inadequate handling; improper or inadequate wiring utilized or installed in connection with the Product; installation, operation or use of the Product not made in strict accordance with the specifications and written instructions provided by IMS; use of the Product for any purpose other than those for which it was designed; ordinary wear and tear; disasters or Acts of God; unauthorized attachments, alterations or modifications to the Product; the misuse or failure of any item or equipment connected to the Product not supplied by IMS; improper maintenance or repair of the Product; or any other reason or event not caused by IMS.

IMS HEREBY DISCLAIMS ALL OTHER WARRANTIES, WHETHER WRITTEN OR ORAL, EXPRESS OR IMPLIED BY LAW OR OTHERWISE, INCLUDING WITHOUT LIMITATION, **ANY WARRANTIES OF MERCHANTABILITY OR FITNESS FOR ANY PARTICULAR PURPOSE**. CUSTOMER'S SOLE REMEDY FOR ANY DEFECTIVE PRODUCT WILL BE AS STATED ABOVE, AND IN NO EVENT WILL THE IMS BE LIABLE FOR INCIDENTAL, CONSEQUENTIAL, SPECIAL OR INDIRECT DAMAGES IN CONNECTION WITH THE PRODUCT.

This Limited Warranty shall be void if the Customer fails to comply with all of the terms set forth in this Limited Warranty. This Limited Warranty is the sole warranty offered by IMS with respect to the Product. IMS does not assume any other liability in connection with the sale of the Product. No representative of IMS is authorized to extend this Limited Warranty or to change it in any manner whatsoever. No warranty applies to any party other than the original Customer.

IMS and its directors, officers, employees, subsidiaries and affiliates shall not be liable for any damages arising from any loss of equipment, loss or distortion of data, loss of time, loss or destruction of software or other property, loss of production or profits, overhead costs, claims of third parties, labor or materials, penalties or liquidated damages or punitive damages, whatsoever, whether based upon breach of warranty, breach of contract, negligence, strict liability or any other legal theory, or other losses or expenses incurred by the Customer or any third party.

OBTAINING WARRANTY SERVICE

Warranty service may be obtained by a distributor, if the Product was purchased from IMS by a distributor, or by the Customer directly from IMS, if the Product was purchased directly from IMS. Prior to returning the Product for service, a Returned Material Authorization (RMA) number must be obtained. Complete the form at <http://www.imshome.com/rma.html> after which an RMA Authorization Form with RMA number will then be faxed to you. Any questions, contact IMS Customer Service (860) 295-6102.

Include a copy of the RMA Authorization Form, contact name and address, and any additional notes regarding the Product failure with shipment. Return Product in its original packaging, or packaged so it is protected against electrostatic discharge or physical damage in transit. The RMA number MUST appear on the box or packing slip. Send Product to: Intelligent Motion Systems, Inc., 370 N. Main Street, Marlborough, CT 06447.

Customer shall prepay shipping charges for Products returned to IMS for warranty service and IMS shall pay for return of Products to Customer by ground transportation. However, Customer shall pay all shipping charges, duties and taxes for Products returned to IMS from outside the United States.

