



MOTION CONTROL [with optional CANopen]

STANDARD FEATURES

- Highly Integrated, High Performance Microstepping Driver and Motion Controller
- Advanced 2nd Generation Current Control for Exceptional Performance and Smoothness
- Single Supply: +12 to +48 VDC
- Low Cost
- Extremely Compact
- High Output Current (per phase) up to **3 Amps RMS, 4.2 Amps Peak**
- Auxiliary Logic Power Supply Input
- 20 Microstep Resolutions up to 51,200 Steps Per Rev Including: Degrees, Metric, Arc Minutes
- Open or Optional Closed Loop Control
- Programmable Motor Run and Hold Currents
- Four +5 to +24 VDC I/O Lines Accept Sourcing or Sinking Outputs
- One 10 Bit Analog Input Selectable: 0 to +10VDC, 0 to +5VDC, 0-20mA, 4-20mA
- 0 to 5MHz Step Clock Rate Selectable in 0.59Hz Increments
- RS-422/485 or Optional CANopen* Communications
- 62 Software Addresses for Multi-Drop Communications
- Simple 1 to 2 Character Instructions
- Power and Signal Interface Options:
 - Pluggable Terminal Strip
 - 12.0" (30.5cm) Flying Leads

EXPANDED PLUS² FEATURES

- +5 to +24 VDC Tolerant I/O Lines Sourcing or Sinking, Inputs and Outputs:
 - 8 I/O Lines with Electronic Gearing (or)
 - 4 I/O Lines with External/Remote Encoder for Closed Loop Control
- High Speed Position Capture Input or Trip Output
- Pluggable Locking Wire Crimp Interface

* CANopen may not support some objects.

DESCRIPTION

The ultra compact **Motion Control MForce MicroDrive** offers system designers a low cost, high performance microstepping driver integrated with an intelligent, programmable motion controller.

The unsurpassed smoothness and performance delivered by MForce MicroDrives are achieved through IMS's advanced 2nd generation current control. By applying innovative techniques to control current flow through the motor, resonance is significantly dampened over the entire speed range and audible noise is reduced.

Motion Control MForce MicroDrives accept a broad input voltage range from +12 to +48 VDC, delivering enhanced performance and speed. Oversized input capacitors are used to minimize power line surges, reducing problems that can occur with long runs and multiple drive systems. An extended operating range of -40° to +85°C provides long life, trouble free service in demanding environments.

A high, per phase output current of up to 3 Amps RMS, 4.2 Amps Peak, allows the extremely compact MForce MicroDrive to control a broad array of motors from size 8 to size 34.

Standard features include four +5 to +24 volt general purpose I/O lines, one 10 bit analog input, 0 to 5MHz step clock rate, 20 microstep resolutions up to 51,200 steps per revolution, and full featured easy-to-program instruction set.

Expanded features in the Plus² version include up to eight +5 to +24 volt general purpose I/O lines and the capability of electronic gearing by following a rotary or linear axis at an electronically controlled ratio, or an output clock can be generated fixed to the internal step clock.

Motion Control MForce MicroDrive Plus² are available with optional closed loop control. This increases functionality by adding stall detection, position maintenance and find index mark. The closed loop configuration offers an expanded choice of line counts and resolutions by interfacing to a remotely mounted user-supplied external encoder.

Motion Control MForce MicroDrives communicate over RS-422/485 which allows for point-to-point or multiple unit configurations utilizing one communication port. Addressing and hardware support up to 62 uniquely addressed units communicating over a single line. Baud rate is selectable from 4.8 to 115.2kbps.

Optional communication protocols include CANopen. The CAN bus is 2.0B active (11 and/or 29 bit) and is capable of all standard frequencies from 10kHz to 1MHz. CANopen features include node guarding, heartbeat producer, SDOs and PDOs. Highlights include variable PDO mapping and extended node identifier.*

Power and signal interface connections are accomplished using 12.0" (30.5cm) flying leads or a 7 position terminal strip. Plus² versions come with pluggable locking wire crimp connector. Motor phases are connected via a pluggable 4-pin locking wire crimp connector.

MForce connectivity has never been easier with options ranging from all-inclusive QuickStart Kits to individual interfacing cables and mating connector kits to build your own cables. *See pg 4.*

The Motion Control MForce MicroDrive is a compact, powerful and inexpensive solution that will reduce system cost, design and assembly time for a large range of applications.

MForce MicroDrive – MOTION CONTROL

STANDARD SPECIFICATIONS (Plus Versions)

INPUT VOLTAGE (+V)	Range	+12 to +48 VDC <i>Power supply current requirements = 3.2A (maximum) per MForce MicroDrive. Actual power supply current will depend on voltage and load.</i>		
	AUX. LOGIC INPUT VOLTAGE	Range	+12 to +24 VDC <i>Maintains power to control and feedback circuits (only) when input voltage is removed.</i>	
OUTPUT CURRENT	RMS (Max)	3 Amps		
	Peak (Per Phase)	4.2 Amps		
ANALOG INPUT	Resolution	10 Bit		
	Voltage Range	0 to +5 VDC, 0 to +10 VDC, 0-20 mA, 4-20 mA		
GENERAL PURPOSE I/O	Number/Type	4 Sinking Outputs/4 Sourcing or Sinking Inputs		
	Logic Range	Inputs and Outputs Tolerant to +24VDC, Inputs TTL Level Compatible		
	Output Sink Current	Up to 600 mA per Channel		
	Protection	Over Temp, Short Circuit, Transient Over Voltage, Over Voltage, Inductive Clamp		
COMMUNICATION	Type (Standard)	RS-422/485		
	Baud Rate	4.8 to 115.2kbps		
	Type (Optional)	CANopen DSP-402 (V2.0), DS-301 (V3.0), 2.OB Active		
	ID	11 and/or 29 Bit		
	Isolation	Galvanic		
	Features	Node Guarding, Heartbeat, SDOs, PDOs (Variable Mapping)		
MOTION	Open Loop Configuration	Number of Settings	20	
		Steps Per Revolution	200, 400, 800, 1000, 1600, 2000, 3200, 5000, 6400, 10000, 12800, 20000, 25000, 25600, 40000, 50000, 51200, 36000 (0.01 deg/μstep), 21600 (1 arc minute/μstep), 25400 (0.001mm/μstep)	
	Counters	Type	Position, Encoder/32 Bit	
		Edge Rate (Max)	5 MHz	
	Velocity	Range	+/- 5,000,000 Steps Per Second	
		Resolution	0.5961 Steps Per Second	
	Accel/Decel	Range	1.5 x 10 ⁹ Steps Per Second ²	
		Resolution	90.9 Steps Per Second ²	
SOFTWARE	Program Storage	Type/Size	Flash/6384 Bytes	
	User Registers	(4) 32 Bit		
	User Program Labels and Variables	192		
	Math Functions	+, -, x, ÷, >, <, =, <=, >=, AND, OR, XOR, NOT		
	Branch Functions	Branch & Call		
	General Purpose I/O Functions	Inputs	Home, Limit Plus, Limit Minus, Go, Stop, Pause, Jog Plus, Jog Minus, Analog In, General Purpose	
		Outputs	Moving, Fault, Stall, Velocity Change, General Purpose	
	Trip Functions	Trip on Input, Trip on Position, Trip on Time, Trip Capture		
	Party Mode Addresses	62		
	Encoder Functions	Stall Detection, Position Maintenance, Find Index		
THERMAL	Heat Sink Temperature	-40° to +85°C		

EXPANDED SPECIFICATIONS (Plus² Versions)

GENERAL PURPOSE I/O	Number/Type	8 Sourcing or Sinking Outputs/Inputs (or 4 when Remote Encoder Option is Selected)		
	Logic Range	Sourcing Outputs +12 to +24 VDC, Inputs and Sinking Outputs Tolerant to +24 VDC, Inputs TTL Level Compatible		
	Output Sink/Source Current	Up to 600 mA per Channel		
MOTION	Electronic Gearing	Range [‡] /Resolution/Threshold (External Clock In)		0.001 to 2.000/32 Bit/TTL
		Input Filter Range		50 nS to 12.9 μS (10 MHz to 38.8 kHz)
		Range [‡] (Secondary Clock Out)		1 to 1
	High Speed I/O	Position Capture	Input Filter Range	50 nS to 12.9 μS (10 MHz to 38.8 kHz)
			Resolution	32 Bit
		Trip Output – Speed/Resolution/Threshold		150 nS/32 Bit/TTL
	Closed Loop Configuration (Optional)	Remote Encoder	Type	User-Supplied Differential Encoder
			Steps Per Revolution	See "Standard Specs Open Loop Steps/Rev" Above
		Resolution	User-Defined Note: μstep/rev 2X the encoder count/rev minimum	

[‡] Adjusting the microstep resolution can increase the range.

MOTOR RECOMMENDATIONS

IMS PART NUMBERS	Size 14 (0.75 Amps)	Size 17 (1.5 Amps)	Size 23 (2.4 Amps)	Size 23 (3.0 Amps)
SINGLE LENGTH	M-1410-0.75	M-1713-1.5	M-2218-2.4	M-2218-3.0
DOUBLE LENGTH	—	M-1715-1.5	M-2222-2.4	M-2222-3.0
TRIPLE LENGTH	—	M-1719-1.5	M-2231-2.4	M-2231-3.0

PIN/WIRE ASSIGNMENTS

P1: I/O & POWER CONNECTOR		
PLUS – Standard Features		
Pluggable Terminal Strip	Flying Leads Wire Colors	Function
Pin 1	White/Yellow	I/O 1
Pin 2	White/Orange	I/O 2
Pin 3	White/Violet	I/O 3
Pin 4	White/Blue	I/O 4
Pin 5	Green	Analog Input
Pin 6	Black	Power/Aux Ground
Pin 7	Red	+V (+12 to +48 VDC)
PLUS ² – Expanded Features		
Wire Crimp	Function	
	Expanded I/O	Optional Remote Encoder Closed Loop Control
Pin 1	I/O Power	I/O Power
Pin 2	I/O Ground	I/O Ground
Pin 3	I/O 1	I/O 1
Pin 4	I/O 2	I/O 2
Pin 5	I/O 3	I/O 3
Pin 6	I/O 4	I/O 4
Pin 7	I/O 9	Channel A +
Pin 8	I/O 10	Channel A -
Pin 9	I/O 11	Channel B +
Pin 10	I/O 12	Channel B -
Pin 11	Capture/Trip I/O	Capture/Trip I/O
Pin 12	Analog In	Analog In
Pin 13	Step/Clock I/O	Index +
Pin 14	Direction/Clock I/O	Index -
Pin 15	+V (+12 to +48 VDC)	+V (+12 to +48 VDC)
Pin 16	Power/Aux Ground	Power/Aux Ground

P2: COMM CONNECTOR		
RS-422/485		
10-Pin IDC	Wire Crimp	Function
Pin 1	Pin 9	TX +
Pin 2	Pin 10	TX -
Pin 3	Pin 7	RX +
Pin 4	Pin 8	RX -
Pin 5	Pin 5	Aux-Logic (+12 to +24 VDC)
Pin 6	Pin 6	RX +
Pin 7	Pin 3	RX -
Pin 8	Pin 4	TX -
Pin 9	Pin 1	TX +
Pin 10	Pin 2	Comm Ground
CANopen		
DB9	Function	
Pin 1	No Connect	
Pin 2	CAN Low	
Pin 3	CAN -V	
Pin 4	Aux Power	
Pin 5	Shield	
Pin 6	CAN -V	
Pin 7	CAN High	
Pin 8	No Connect	
Pin 9	CAN +V	
P3: MOTOR CONNECTOR		
Pluggable Locking Wire Crimp	Function	
Pin 1	Phase /A	
Pin 2	Phase A	
Pin 3	Phase /B	
Pin 4	Phase B	

MECHANICAL SPECIFICATIONS

Dimensions in Inches (mm)

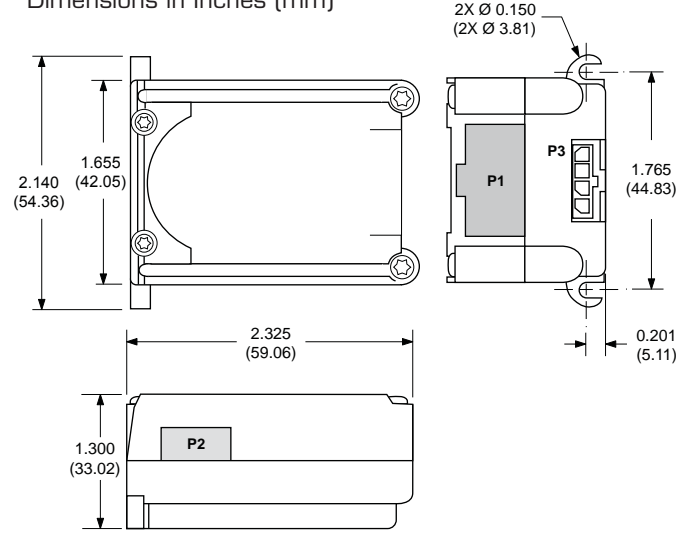

P1 Connector Options

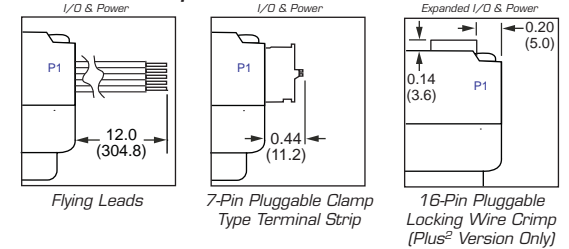

P2 Connector Options

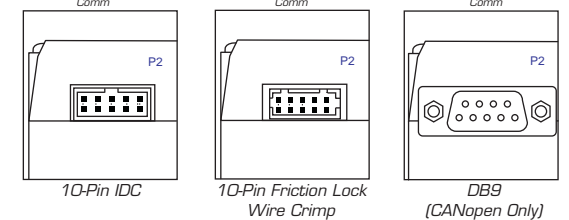

MOTOR PERFORMANCE

Speed-Torque

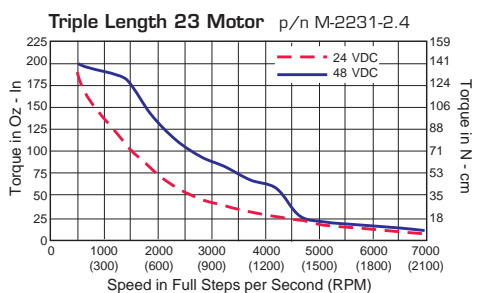
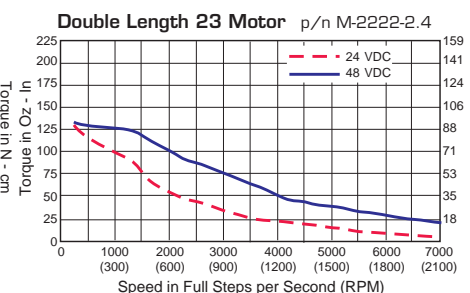
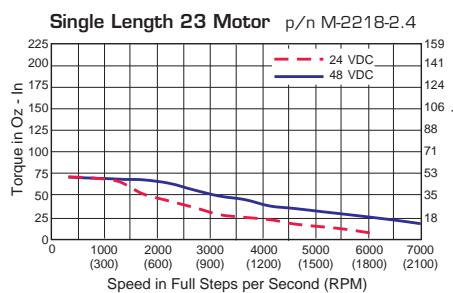
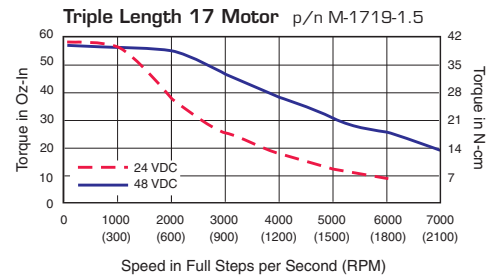
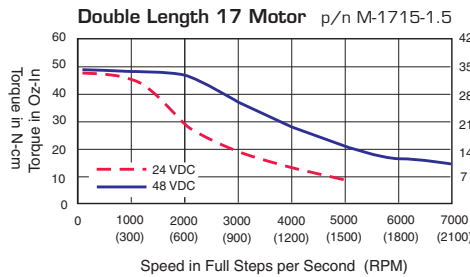
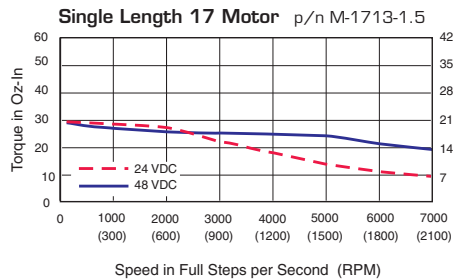

MForce MicroDrive – MOTION CONTROL

CONNECTIVITY

new QuickStart Kit

For rapid design verification, all-inclusive QuickStart Kits have communication converter, prototype development cable(s), instructions and CD for MForce initial functional setup and system testing.

new Communication Converters

Electrically isolated, in-line converters pre-wired with mating connectors to conveniently set/program communication parameters for a single MForce via a PC's USB port. Length 12.0' (3.6m).

Mates to connector:

10-Pin IDCMD-CC400-001
 10-Pin Wire CrimpMD-CC402-001
 DB9 CANopenMD-CC500-000*

*Requires mating connector adapter and power supply, not supplied.

Prototype Development Cables

Speed test/development with pre-wired mating connectors that have flying leads other end. Length 10.0' (3.0m).

Mates to connector:

10-Pin Wire CrimpPD10-1434-FL3
 16-Pin Wire CrimpPD16-1417-FL3
 4-Pin Wire CrimpPDO4-MF17-FL3

new Mating Connector Kits

Use to build your own cables. Kit contains 5 mating shells with pins. Cable not supplied. Manufacturer's crimp tool recommended.

Mates to connector:

10-Pin Wire CrimpCK-02
 16-Pin Wire CrimpCK-10
 4-Pin Wire CrimpCK-06

Kit contains 5 mating connectors that press fit onto ribbon cable. Cable not supplied.

10-Pin IDCCK-01

OPTIONS

Motors

IMS offers a wide range of motors and accessories, recommended for interface with the MForce MicroDrive. For specifications on these products, go to www.imshome.com.

Connectivity details: www.imshome.com/mforce_connectivity.html

PART NUMBERING



Plus

K MF1 **17N4**

QuickStart Kit details above

P1: I/O & Power
 F = 12" Flying Leads
 P = Pluggable Clamp Type Terminal Strip

P3: Motor Interface
 4-Pin Locking Wire Crimp

P2: Communications
 RD = RS-422/485 with 10-Pin IDC Connector
 RL = RS-422/485 with 10-Pin Friction Lock Wire Crimp
 CB = CANopen with DB9 Connector

Example: Part Number **MF1PRD17N4** is a Motion Control MForce MicroDrive Plus with pluggable I/O & power interface, RS-422/485 communications with 10-pin IDC connector and 4-pin motor interface.



Plus²

K MF13C **17N4** - **OPTION EE**

QuickStart Kit details above

P1: I/O & Power
 16-Pin Locking Wire Crimp

P3: Motor Interface
 4-Pin Locking Wire Crimp

P2: Communications
 RD = RS-422/485 with 10-Pin IDC Connector
 RL = RS-422/485 with 10-Pin Friction Lock Wire Crimp
 CB = CANopen with DB9 Connector

Remote Encoder Interface
 For Closed Loop Control (Encoder Not Supplied)

Example: Part Number **MF13CRD17N4** is a Motion Control MForce MicroDrive Plus² with 16-pin I/O & power interface, RS-422/485 communications with 10-pin IDC connector and 4-pin motor interface.

Option: Include -EE to part number for optional interface to remote encoder (not supplied). *Plus² versions only.*

U.S.A. SALES OFFICES

Eastern Region

Tel. 862 208-9742 - Fax 973 661-1275
 e-mail: e.region@imshome.com

Northeast Region

Tel. 860 368-9703
 e-mail: n.region@imshome.com

Central Region

Tel. 860 295-6102
 e-mail: c.region@imshome.com

Western Region

Tel. 602 578-7201
 e-mail: w.region@imshome.com

IMS EUROPEAN SALES MANAGEMENT

4 Quai Des Etroits, 69005 Lyon, France
 Tel. +33/4 7256 5113 - Fax +33/4 7838 1537
 e-mail: europe.sales@imshome.com

IMS ASIA PACIFIC OFFICE

30 Raffles Pl., 23-00 Chevron House, Singapore 048622
 Tel. +65/6233/6846 - Fax +65/6233/5044
 e-mail: asia.sales@imshome.com

TECHNICAL SUPPORT

Tel. +00 (1) 860 295-6102 - Fax +00 (1) 860 295-6107
 e-mail: etech@imshome.com

Intelligent Motion Systems, Inc.

370 North Main Street, P.O. Box 457
 Marlborough, CT 06447 - U.S.A.
 Tel. +00 (1) 860 295-6102 - Fax +00 (1) 860 295-6107
 e-mail: info@imshome.com
<http://www.imshome.com>

© Intelligent Motion Systems, Inc. All Rights Reserved. REV072709
 IMS Product Disclaimer and most recent product information at www.imshome.com.

IMS
 is becoming

Schneider
 Electric

IMSTM

**INTELLIGENT MOTION
 SYSTEMS, INC.**